

# Hanwha Solutions Wire & Cable Division- Sustainable Handling & Packaging for Cable Insulation Materials



# Contents

<b>01. Company Overview</b>	<b>3p</b>
<b>02. Introduction</b>	<b>4p</b>
<b>03. Product Portfolio</b>	<b>5p</b>
<b>04. Product Information</b>	<b>8p</b>
<b>05. Packaging Information</b>	<b>10p</b>
① XLPE	16p
② Semicon	18p
③ Jacket	19p
④ Flecon Bag	21p
⑤ JID 25kg	22p
⑥ FFS 25kg	23p
⑦ Wooden Pallet	24p
⑧ Handling, Storage & Transportation Guidelines	28p



# Hanwha Solutions Wire & Cable Division— Builds a better tomorrow With clean technology

Hanwha Solutions Wire & Cable Division is a leading global provider of advanced insulation and semiconductive materials for power and communication cables.

With decades of polymer expertise and a strong commitment to innovation, we deliver clean, high-performance, and sustainable compound solutions that meet the evolving needs of modern energy infrastructure.

Our materials are trusted in Super Extra High Voltage (SEHV), Extra-High Voltage (EHV), High Voltage (HV), and Medium Voltage (MV) power transmission cables, as well as low-voltage building wires and communication cables.

Each product is engineered to enhance reliability, processability, and long-term system performance.

Driven by the philosophy of “Clean Manufacturing, Safe Delivery,”

Hanwha Solutions has established a fully integrated system from polymer synthesis to packaging and logistics to ensure purity, consistency, and traceability across the entire supply chain.

Through continuous R&D and sustainable process innovation, we are expanding our global production capacity and strengthening our position as a trusted materials partner around the globe.

By adopting eco-friendly packaging with recycled polyethylene (rPE) and improving process efficiency, we contribute to a cleaner planet and a more resilient energy network.

Our mission is simple:  
To power the world’s energy transition through innovation, integrity, and sustainability.

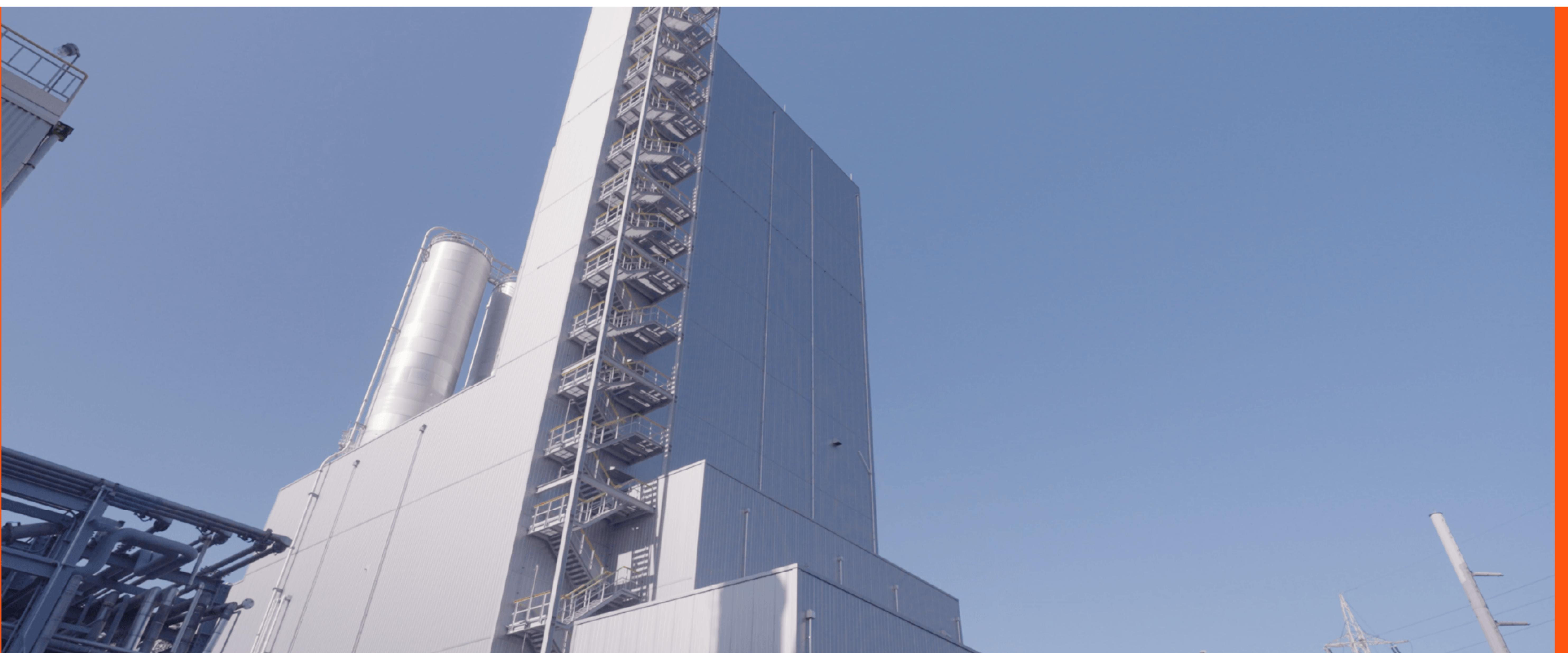

# Introduction

## Eco-Friendly Packaging Innovation

Hanwha Solutions Wire & Cable Division puts environmental responsibility at the core of its packaging process.

Our packaging bags are made using recycled polyethylene (rPE), reflecting the Hanwha Group's strong commitment to sustainability and ESG management.

By using rPE for packaging, we also reduce the carbon footprint of our products, supporting our partners in meeting their decarbonization targets.

We plan to expand the use of recycled materials across all packaging applications, creating a fully eco-friendly value chain — from material production to packaging and logistics.



## High-Clean Logistics Design for Premium Compounds

Hanwha Solutions Wire & Cable Division manufactures high-purity and super-clean insulation and semicon compounds for extra-high-voltage power cables.

To preserve this level of quality, we operate a precision-engineered packaging and logistics system.

Sealed packaging structure designed to prevent contamination, moisture, and static electricity.

Closed-loop logistics flow from factory to customer extruder for ultimate cleanliness.

Packaging designed not just for transport, but for complete product protection.

# PRODUCT PORTFOLIO



# Product Portfolio

## XLPE & SEMICON

We started Wire & Cable business in 1981, producing clean XLPE and SEMICON by using our own produced LDPE, EVA and EBA as base resin.

Currently, Hanwha's Wire & Cable compound production capacity is up to 110kta for insulation(Power Cable) and 10kta for Semicon. Recently, we have expanded our production capacity of SEMICON(+8kta) on AUG 2024, and planning for additional expansion of XLPE (+50kta) by 2029.

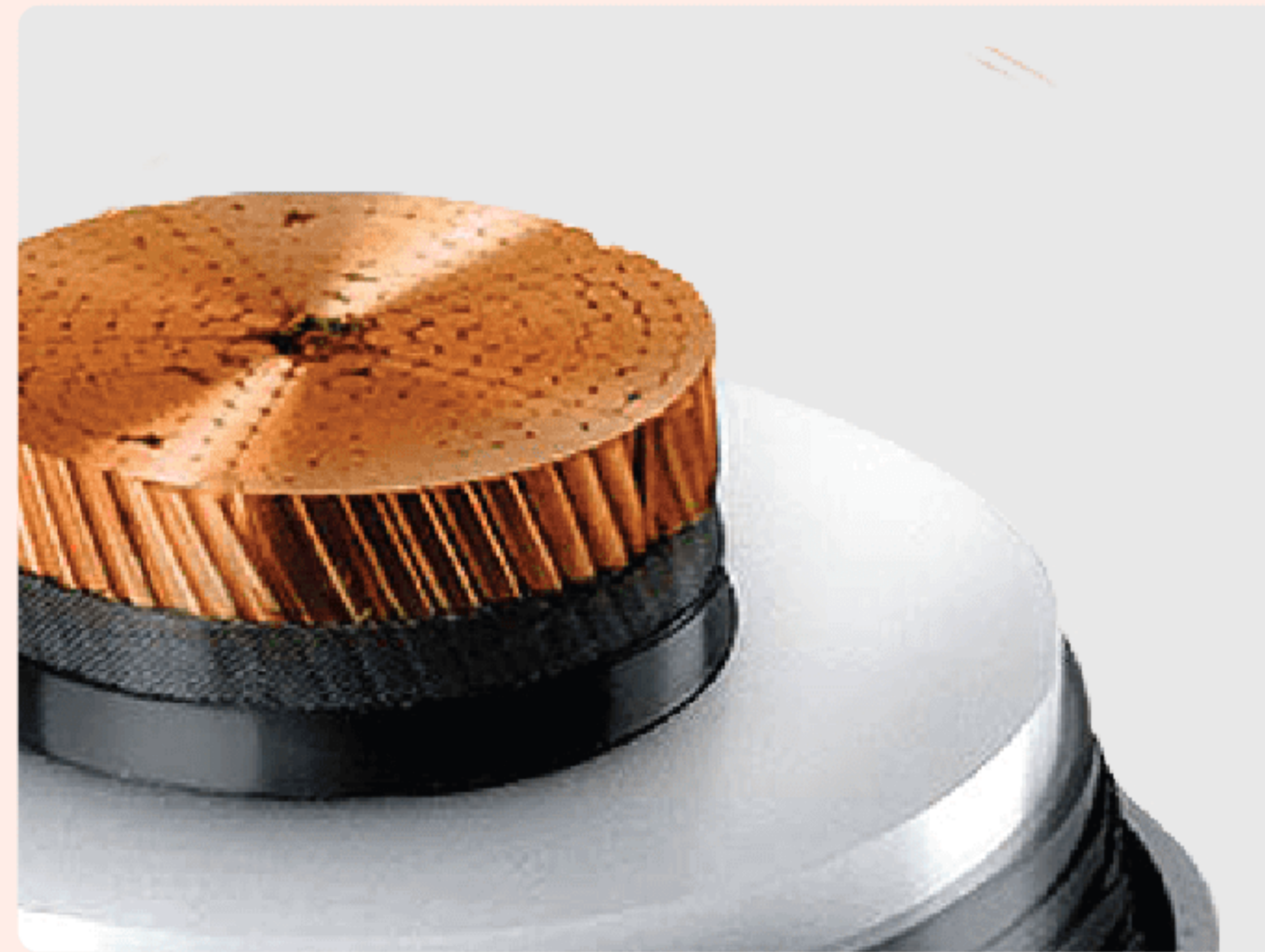

## Power Cable Compounds

Class	Property Grade	Melt Index	Density	Tensile Strength at Break	Elongation at Break	Application
		g/10min	g/cm <sup>3</sup>	kgf/cm <sup>2</sup>	%	
LV Power Cable Insulation	CLNA-8262	2.60	0.922	180	800	LLDPE, Base Resin for Silane Crosslinking
MV/HV/EHV/DC Power Cable Insulation	CLNB-8141S	-	0.921	200	550	XLPE for MV Power Cable Insulation (Up to 69kV(Um 72.5kV))
	CLNA-TR8142EC	-	0.922	200	550	Tree Retardant XLPE for URD or Submarine Cable (Up to 69kV(Um 72.5kV))
	CLNA-8141SC	-	0.921	200	550	XLPE for HV Cable Insulation (Up to 161kV(Um 170kV))
	CLNA-8141EHV	-	0.921	200	550	XLPE for EHV Cable Insulation (Up to 230kV(Um 245kV))
	CLNA-8141SEHV	-	0.921	200	550	XLPE for EHV Cable Insulation (Above 230kV(Um 245kV))
	CLNA-8151	-	0.921	200	550	XLPE for DC Power Cable Insulation (Up to 800kV)
HV/EHV Subsea Cable Insulation	CLNS-8141SC	-	0.921	200	550	XLPE for HV Cable Insulation (Up to 161kV(Um 170kV)), Enhanced Long-run Processability, Shorter Degassing time
	CLNS-8141EHV	-	0.921	200	550	XLPE for EHV Cable Insulation (Up to 230kV(Um 245kV)), Enhanced Long-run Processability, Shorter Degassing time
	CLNS-8141SEHV	-	0.921	200	550	XLPE for EHV Cable Insulation (Above 230kV(Um 245kV)), Enhanced Long-run Processability, Shorter Degassing time
Outdoor Cable Insulation	CLBA-8923BK	-	0.932	200	550	Black XLPE for Outdoor Cable Insulation (Up to 36kV), Excellent Tracking Resistance
	CLBB-8923BK	-	0.923	200	550	Black XLPE for Outdoor Cable Insulation (Up to 36kV)
	CLBA-8924BK	-	0.930	200	550	Black XLPE for Outdoor Cable Insulation (Up to 36kV), Excellent Weatherability
Power Cable Semiconductive Shield	CTBA-8720BK	-	1.14	190	200	Conductor and Bonded Insulation Shield for MV Cable (Up to 69kV(Um 72.5kV))
	CTBA-8730BK	-	1.14	190	200	Conductor and Bonded Insulation Shield for MV Cable (Up to 69kV(Um 72.5kV))
	CCBA-8715BK	-	1.14	140	300	Strippable Insulation Shield for EPR and XLPE Cables (Up to 46kV(Um 52kV))
	CCBA-8725BK	-	1.14	140	300	Strippable Insulation Shield for MV Cable (Up to 69kV(Um 72.5kV))
	CCBA-8735BK	-	1.14	140	300	Strippable Insulation Shield for MV Cable (Up to 69kV(Um 72.5kV))
	CTBA-8740BK	-	1.14	150	190	Conductor and Insulation Shield for HV Cable (Up to 161kV(Um 170kV))
	CTBA-8745BK	-	1.14	150	190	Conductor and Insulation Shield for EHV Cable (Up to 230kV(Um 245kV))
	★ CTBA-8750BK	-	1.14	150	190	Conductor and Insulation Shield for EHV Cable (Above 230kV(Um 245kV))
	★ CTBA-8760BK	-	1.14	150	190	Conductor and Insulation Shield for DC Cable (Up to 800kV)

★ Aluminium Liner is applied to 8750BK and 8760BK to protect their electrical stability and cleanliness from moisture and oxygen.

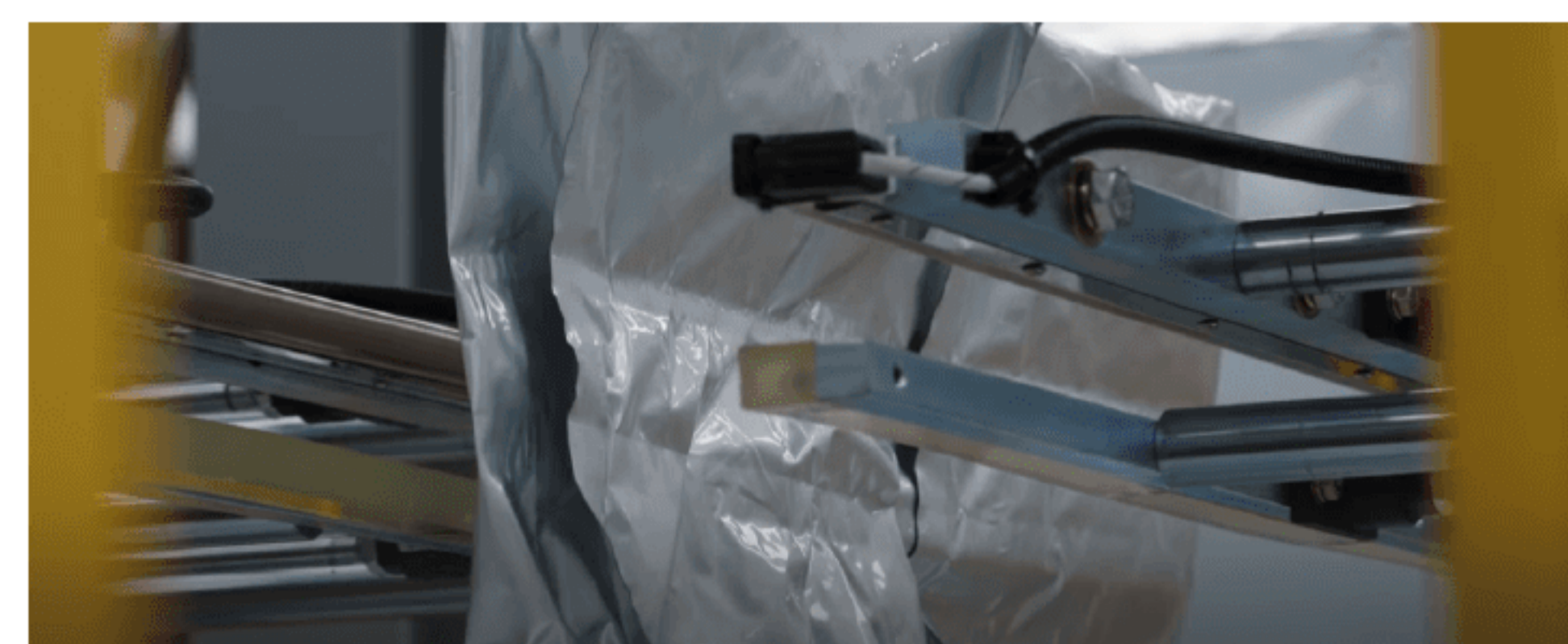

# Product Portfolio

## Telecommunication Cable Compounds

Property Grade	Melt Index	Density	Tensile Strength at Break	Elongation at Break	Application
	g/10min	g/cm <sup>3</sup>	kgf/cm <sup>2</sup>	%	
CHNA-8380	0.7	0.945	240	550	HDPE Insulation for Solid, Skin of Foam/Skin, LAN Cable
CHNA-8380L	0.7	0.945	240	550	HDPE Insulation for High Speed LAN Cable
8600HL	8.5/2.0	0.962/0.921	260/120	500/600	HDPE/LDPE Insulation for Gas Injection Coaxial Cable

\* The data is typical value, not the specification and may be varied depending on the test condition.

## Jacketing Compounds

Property Grade	Melt Index	Density	Tensile Strength at Break	Elongation at Break	Carbon Black Contents	Application
	g/10min	g/cm <sup>3</sup>	kgf/cm <sup>2</sup>	%	%	
CLBB-850BK	0.3	0.933	165	550	2.6	Black LDPE Jacketing Compound
CLNA-8400	0.7	0.920	180	800	-	Natural Colorable LLDPE Jacket, UV stabilizer needs to be blended
CLBA-8450BK	0.8	0.934	200	800	2.5	Black LLDPE Jacketing Compound
CMBA-8240BK	0.2	0.949	300	800	2.5	Black MDPE Jacketing Compound
CHBA-8241BK	0.2	0.955	300	800	2.5	Black HDPE Jacketing Compound
CHBA-8241RC	0.2	0.959	250	800	2.5	Black HDPE Jacketing Compound (50% recycled content)

\* The data is typical value, not the specification and may be varied depending on the test condition.

## EVA for Wire & Cable Compounds

Property Grade	VA Content	Melt Index	Density	Melting Temp	Tensile Strength at Break	Elongation at Break	Hardness (Shore A)	Application
	%	g/10min	g/cm <sup>3</sup>	°C	kgf/cm <sup>2</sup>	%	-	
1815	15	6.0	0.936	88	160	800	93	Base Resin for Inner Semiconductive Compounds
2815	15	6.5	0.936	88	170	800	93	Base Resin for Inner Semiconductive Compounds
1828	28	4.0	0.950	75	200	800	79	Base Resin for Flame Retardant Compounds
1834	33	17.0	0.953	63	105	800	65	Base Resin for Outer Semiconductive Compounds

\* The data is typical value, not the specification and may be varied depending on the test condition.

# PRODUCT INFORMATION



# Product Information

## Packaging Options & FCL Loading Information

### Cable Compound Packaging Solutions

Hanwha Solutions Wire & Cable Division supplies high-performance cable compounds worldwide, offering optimized packaging options tailored to diverse customer needs.

- Multi-layer PE liner film ensures excellent airtightness, moisture protection, and anti-static performance
- Reinforced carton boxes provide superior stacking strength and impact resistance during transportation
- The packaging structure prevents contamination throughout long-distance shipping and storage

Below are the packaging types and FCL loading capacities for each Category.

Category		Packaging	FCL(MT) With Pallet	
			20FT	40FT
XLPE	8141S	Carton Box 550kg (CB550)	11	22
		Carton Box 1,000kg (CB1000)	10	20
	8141SC	Same as 8141S		
	8141EHV			
	8141SEHV			
	8142EC			
8151				
Semicon	8720BK	Carton Box 650kg (CB650)	13	23.4
	8725BK			
	8730BK			
	8735BK			
	8740BK			
	8745BK			
	8750BK			
	8760BK			
Jacket	850BK	Flecon Bag 500kg (FB500)	10	22
		Carton Box 600kg (CB600)	12	23.4
		JID (25kg)	12	24
	8450BK	Carton Box 600kg (CB600)	12	23.4
		Flecon Bag 700kg (FB700)	14	22.4
		JID (25kg)	12	24
	8240BK	Carton Box 600kg (CB600)	12	23.4
		Flecon Bag 700kg (FB700)	14	22.4
		JID (25kg)	12	24
	8241BK	Carton Box 600kg (CB600)	12	23.4
		Flecon Bag 700kg (FB700)	14	22.4
		JID (25kg)	12	24
PE	8380	FFS (25kg)	12	24
		Flecon Bag 750kg (FB750)	15	24
	8262	FFS (25kg)	12	24
		Flecon Bag 500kg (FB500)	10	22
	8400	FFS (25kg)	12	24
		Flecon Bag 650kg (FB650)	13	23.4

# PACKAGING INFORMATION



복합수지  
8141 S  
1426 BH 064  
2026  
018-8MB



WIRE & CABLE  
COMPOUND  
전선용 복합수지

WIRE & CABLE COMPOUND  
전선용 복합수지  
HANDLE WITH CARE  
DO NOT EXPOSE TO FLAME  
DO NOT EXPOSE TO BIOHAZARD  
DO NOT EXPOSE TO BIOHAZARD



NET WT. 550 g  
MADE IN KOREA

# Hanwha Solutions Wire & Cable Compound Packaging Label Guide

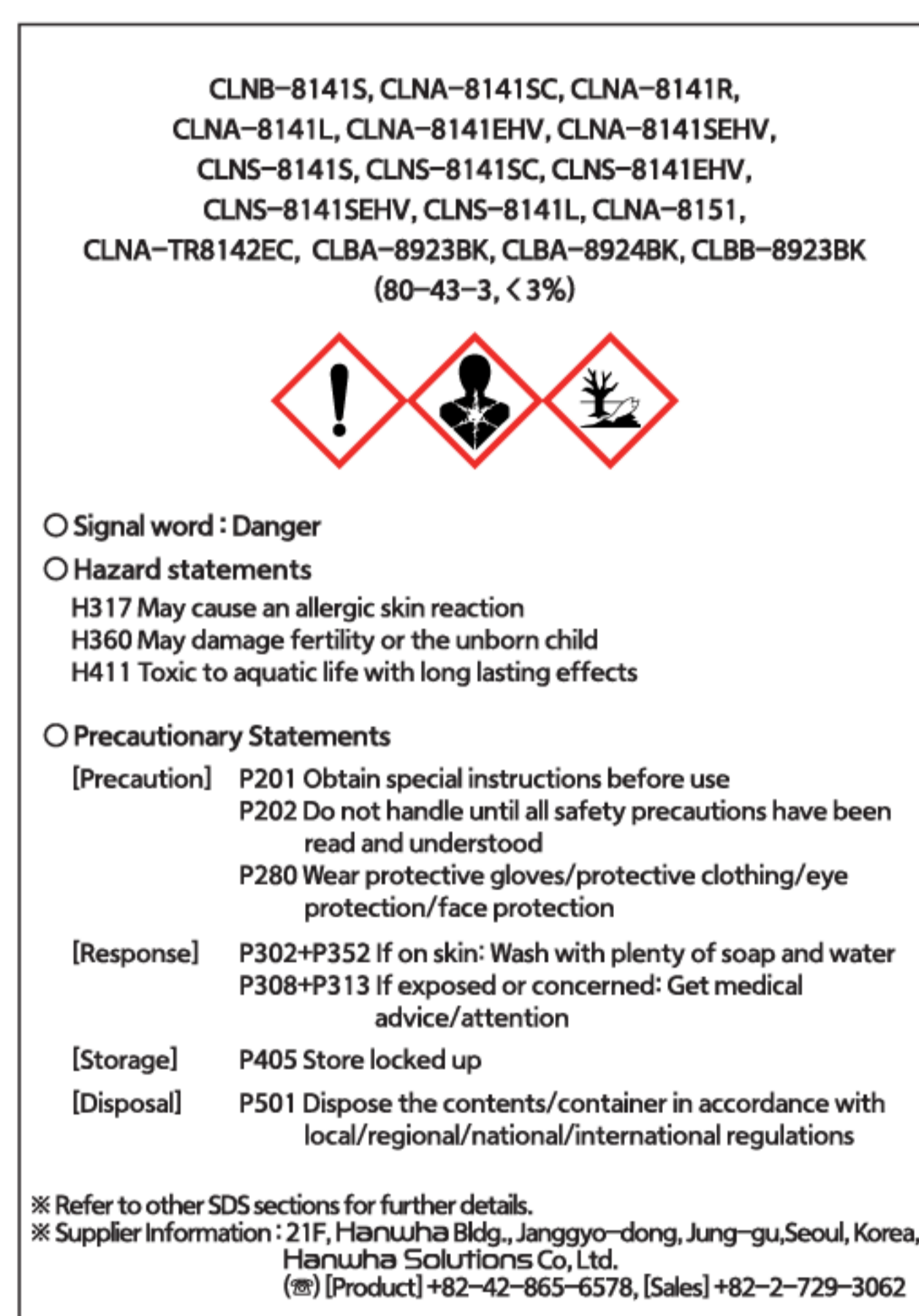

## 1. Symbol

### Safety & Compliance at a Glance

This section displays **internationally standardized safety and hazard symbols** required for proper handling of the product.

Based on the GHS (Globally Harmonized System), these icons clearly communicate potential risks and safety precautions throughout storage, transportation, and on-site handling.

## CAUTION

1. Avoid direct solar radiation, store in cool, dry and ventilated area.
  2. Keep away from heat, spark, and flame.
  3. Do not inhale gas emitted from heated resin.
  4. Direct contact with melted resin may cause severe burns.
  5. The workshop floor should be kept clean in order to prevent accident associated with loose pellets or film.
  6. Avoid inhaling pellet or dust in packaging bags.
  7. Ensure the pellets and packaging bags are disposed of properly and in compliance with local / state regulations.
  8. Lifting of heavy bags can cause damage to your spine if not done correctly.
  9. Care should be taken to avoid accidents when loading, unloading or stacking the product.
  10. If the product is exposed to rain, moisture contamination may occur inside the bag. Please keep the product away from rain, especially when unloading and storing it.
- ※ Please refer to the Material Safety Data Sheet(MSDS) for more details.

Environmental Product Declaration Certification



Hanwha B/D, 1 Janggyo-dong,  
Jung-gu, Seoul, Korea  
wireandcable@hanwha.com  
www.hanwhasolutions.com

**WIRE & CABLE  
COMPOUND**  
전선용 복합수지

## 2. Caution

### Essential Handling Guidelines

This area provides **key instructions for safe storage, handling, and usage** to maintain product quality and performance.

It also includes the **EPD (Environmental Product Declaration) mark**, certifying that the product's environmental impacts have been **quantified and transparently disclosed across its entire life cycle**.



The EPD mark certifies that a product's environmental impacts across its entire life cycle have been quantified and transparently disclosed.

# Hanwha Solutions Wire & Cable Compound Packaging Label Guide

FCL(MT) With Pallet	
20FT	40FT
11	22
10	20

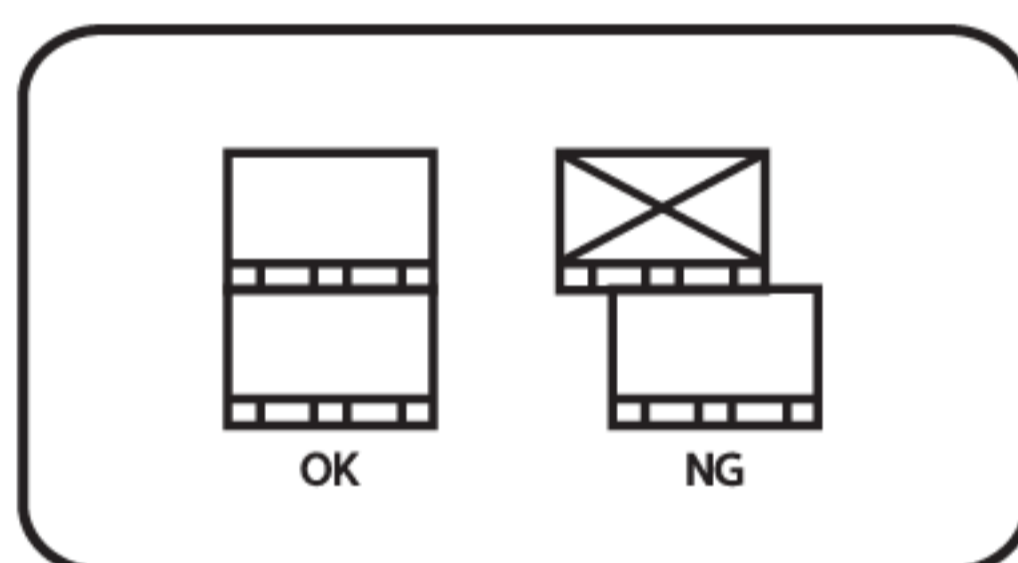
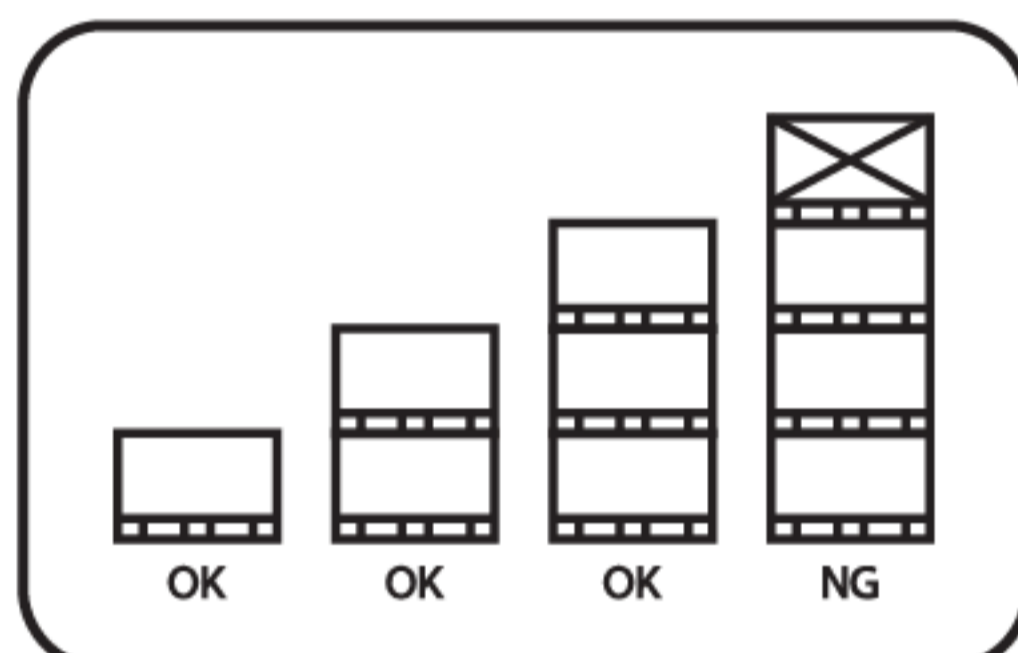

## 3. Stack Info

### Optimized Logistics & Stacking Information

This section visually presents **stacking limits, pallet configurations, and container loading guidelines** for efficient logistics operations.

By clearly indicating correct and incorrect stacking methods, it helps ensure **safe transportation, stable storage, and optimized warehouse utilization.**



## 4. LOT sticker

### Label Information

This section provides detailed information on the product label components to ensure clear identification and traceability.

- **GRADE** : Product Name
- **LOT NO** : Batch Number
- **Number on the right side of LOT NO** : Box Number
- **Production Date** : Displayed in Day – Month – Year format
- **BIS CODE** : Internal product identification and specification code
- **QR CODE** : TDS of the Product

# Advanced Packaging for High-Performance Hanwha Solutions Wire & Cable Materials



## 1. Double Sealing for Safe Handling Extra Taping for Safer Package Opening

To enhance safety during unpacking, our box packaging is finished with an additional taping process.

This double sealing helps prevent accidental paper cuts that may occur when opening cardboard packaging, ensuring a safer and more comfortable handling experience for customers throughout the delivery and opening process.



## 2. Moisture Control with Desiccant Humidity-Controlled Shipping

Moisture control is critical for maintaining the quality and performance of wire and cable compounds during transportation and storage. During container loading, desiccants are installed inside the container to control humidity and prevent condensation, ensuring clean and stable product quality upon delivery.

**Desiccant installation standards :**

- One desiccant set consists of 4 individual desiccant units
- 20-ft container : 6 sets (24 units total)
- 40-ft container : 10 sets (40 units total)
- Desiccants are installed at appropriate positions inside the container to ensure effective moisture absorption throughout transit

This humidity-control system helps protect materials from moisture exposure during long-distance ocean transportation.

# Advanced Packaging for High-Performance Hanwha Solutions Wire & Cable Materials



## 3. Fully Automated Packaging System Automation for Damage Minimization

All packaging processes are operated through a **fully automated system**, eliminating manual handling. This minimizes physical damage during packaging and ensures **uniform, repeatable packaging quality** across all shipments.



## 4. Internal Handling System Protective Pallet Management

To ensure **maximum protection**, all products wrapped with wooden pallets are **handled on plastic pallets** during **internal factory transport**, reducing the risk of damage to both the pallets and the products.

# CARTON BOX INFORMATION



한화전선용 복합수지  
HANWHA WIRE & CABLE COMPOUND  
GRADE C2NB-8141 S  
LOT NO. YW 801426 BH 160  
PRODUCTION DATE 18 JAN 2025  
SIS CODE 9725-1-05-0008

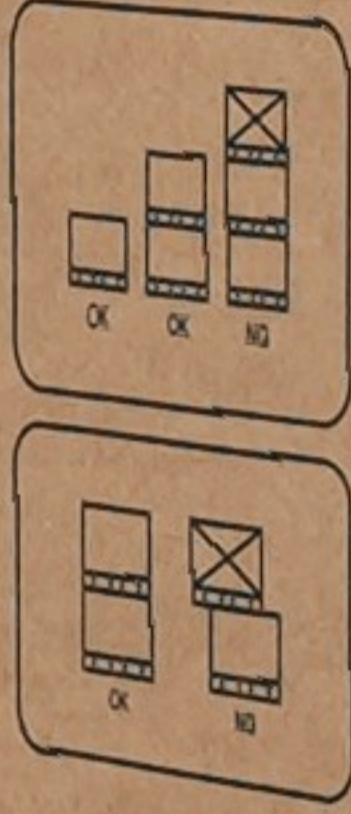

**WIRE & CABLE  
COMPOUND**  
전선용 복합수지

NET WT. 10kg  
MADE IN KOREA

**WIRE & CABLE  
COMPOUND**  
전선용 복합수지

Handling instructions and safety information in Korean and English.



# XLPE Packaging Information (550kg)

Category		Packaging	FCL(MT) With Pallet	
			20FT	40FT
XLPE	8141S	Carton Box 550kg (CB550)	11	22
	8141SC	Same as 8141S		
	8141EHV			
	8141SEHV			
	8142EC			
	8151			



★ CBM

BAG = Ton X 1.600  
BOX = Ton X 2.047

[Unit: mm]



[Unit: mm]

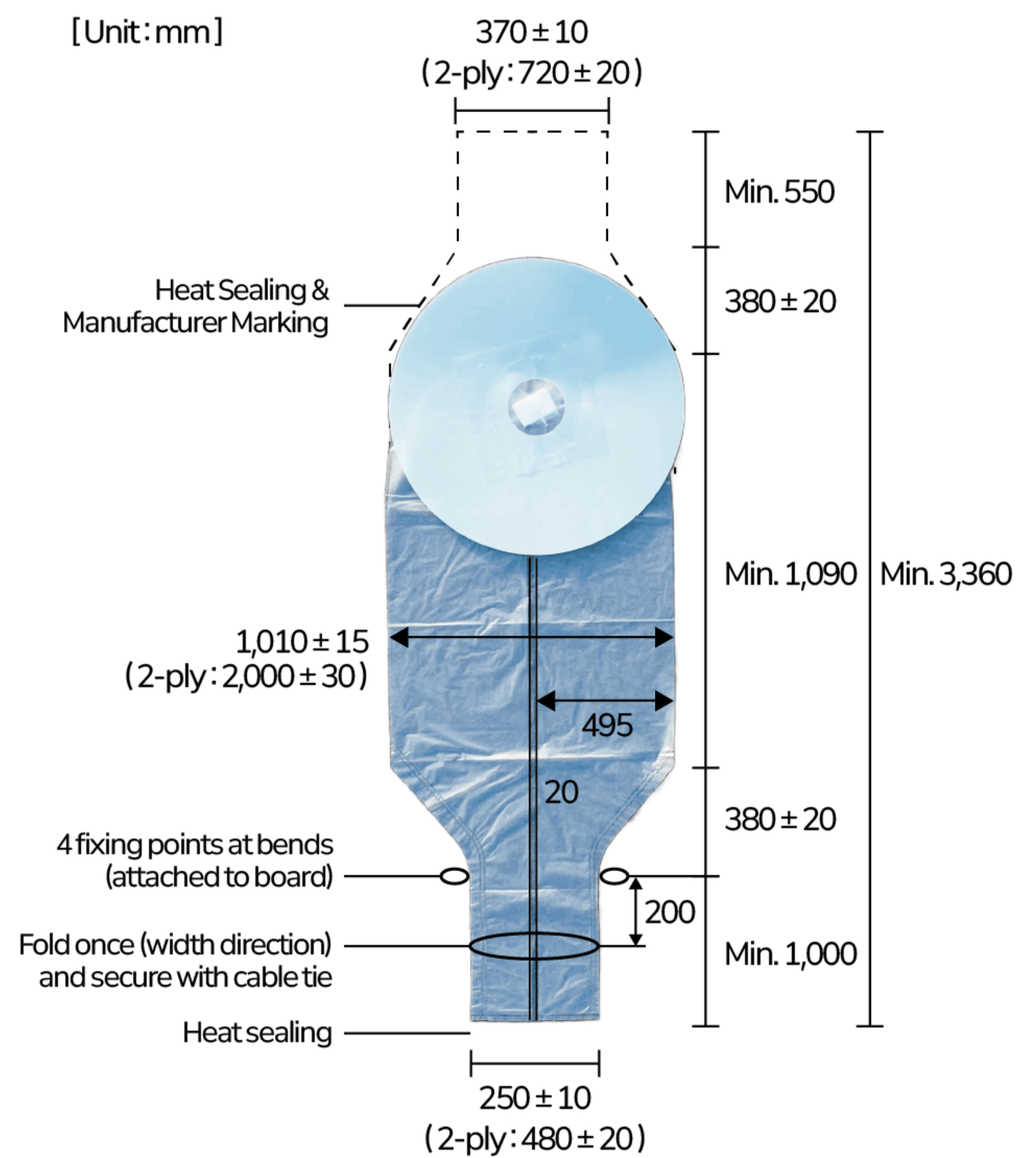

550 kg Packaging

Match Liner Film

XLPE Packaging (550 kg) :  
Maximum stacking height of 3 units per pallet

FCL(MT) With Pallet	
20FT	40FT
11	22

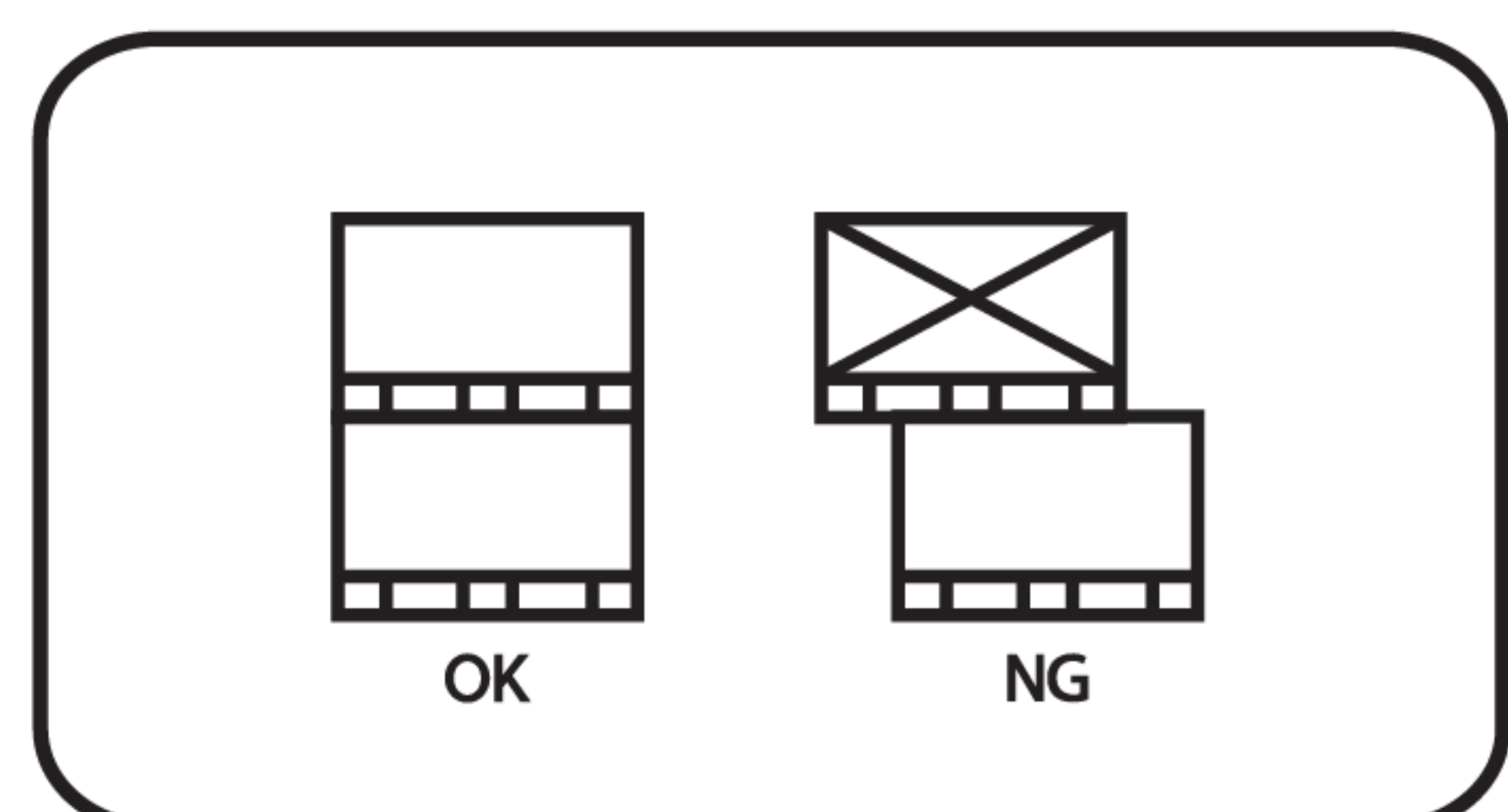
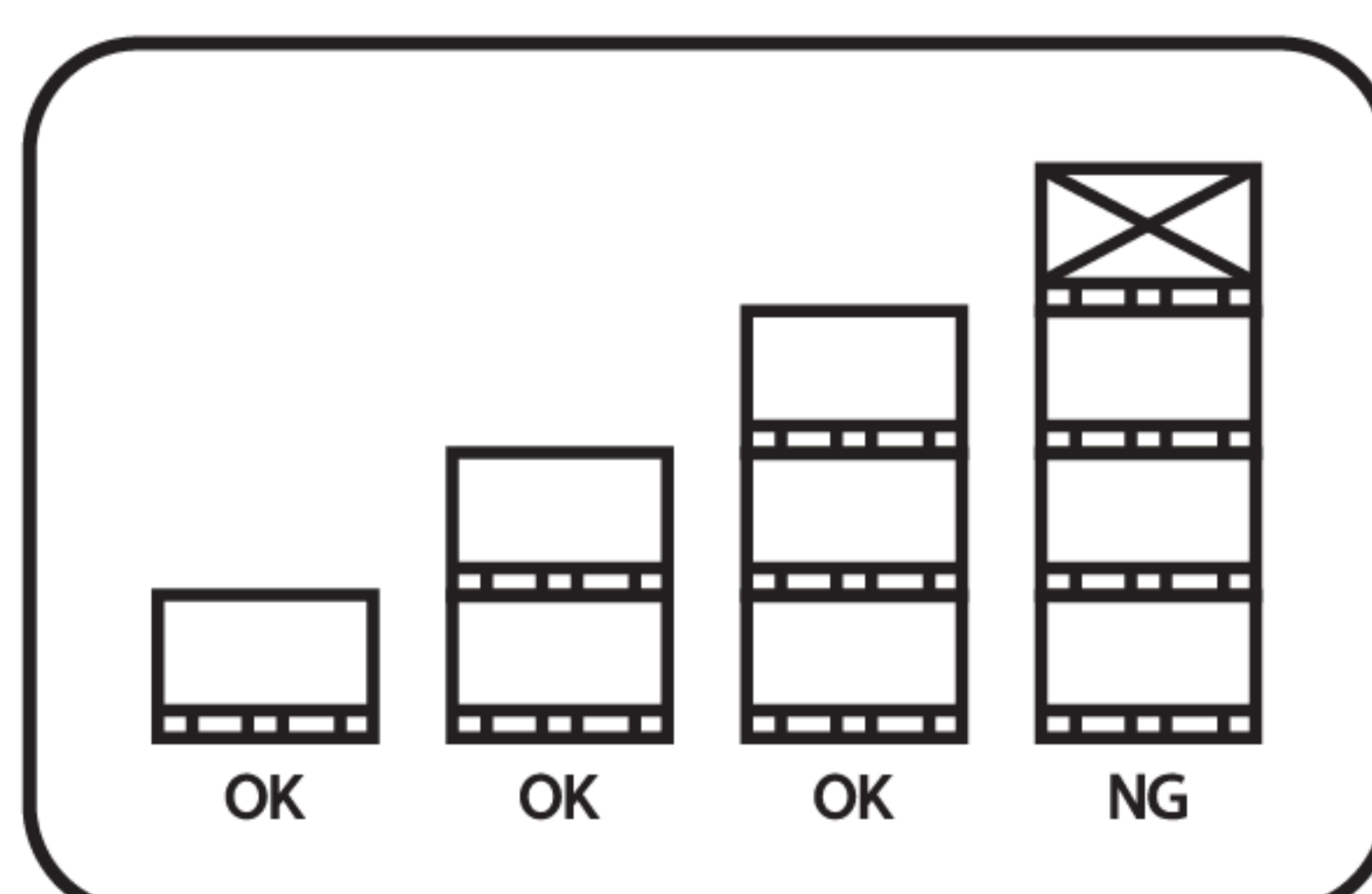

# XLPE Packaging Information (1,000kg)

Category		Packaging	FCL(MT) With Pallet	
			20FT	40FT
XLPE	8141S	Carton Box 1,000kg (CB1000)	10	20
	8141SC	Same as 8141S		
	8141EHV			
	8141SEHV			
	8142EC			
	8151			

[Unit: mm]



1,000 kg Packaging

[Unit: mm]

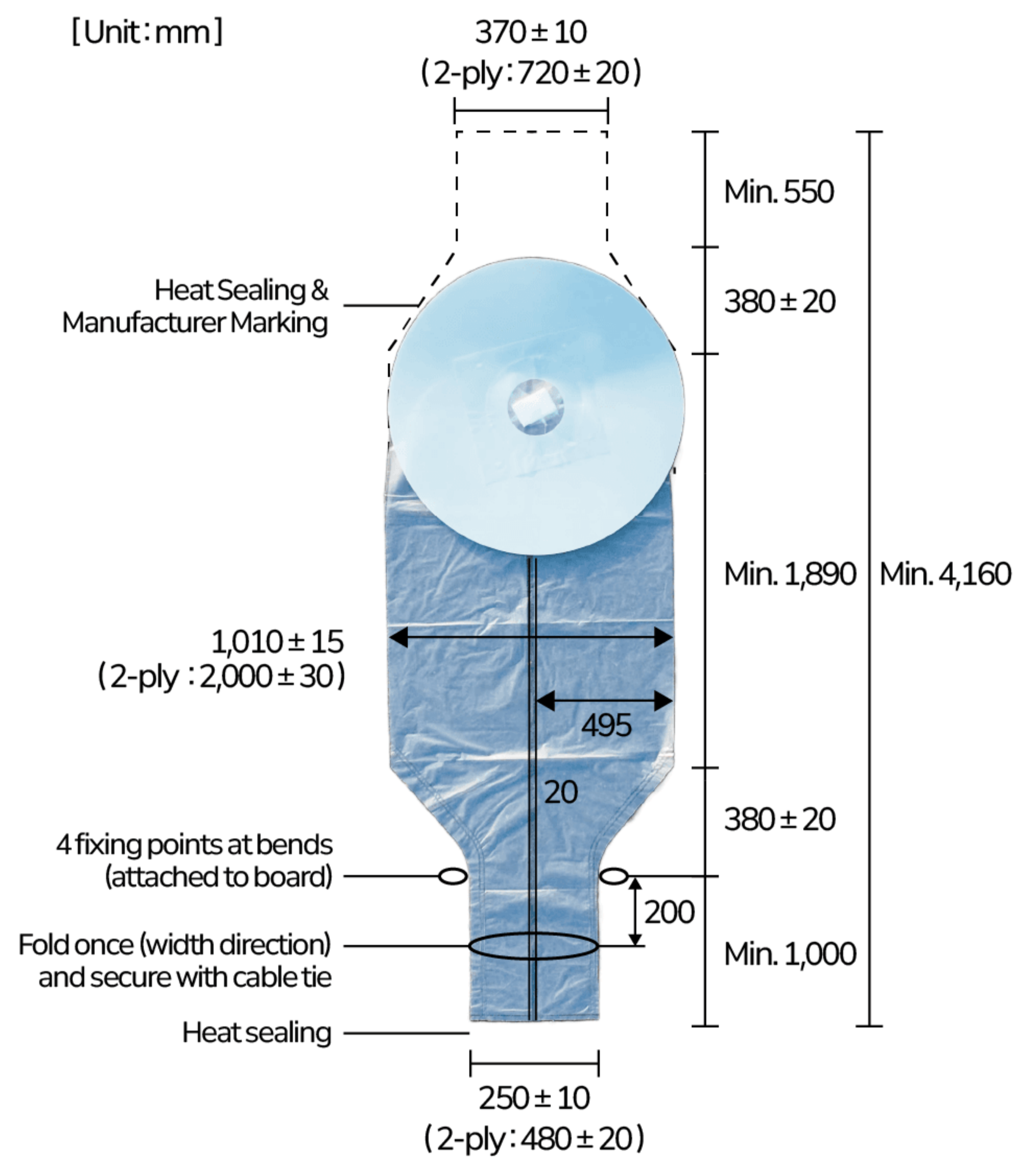

Match Liner Film

**XLPE Packaging (1,000 kg) :**  
Maximum stacking height of 2 units per pallet

FCL(MT) With Pallet	
20FT	40FT
10	20

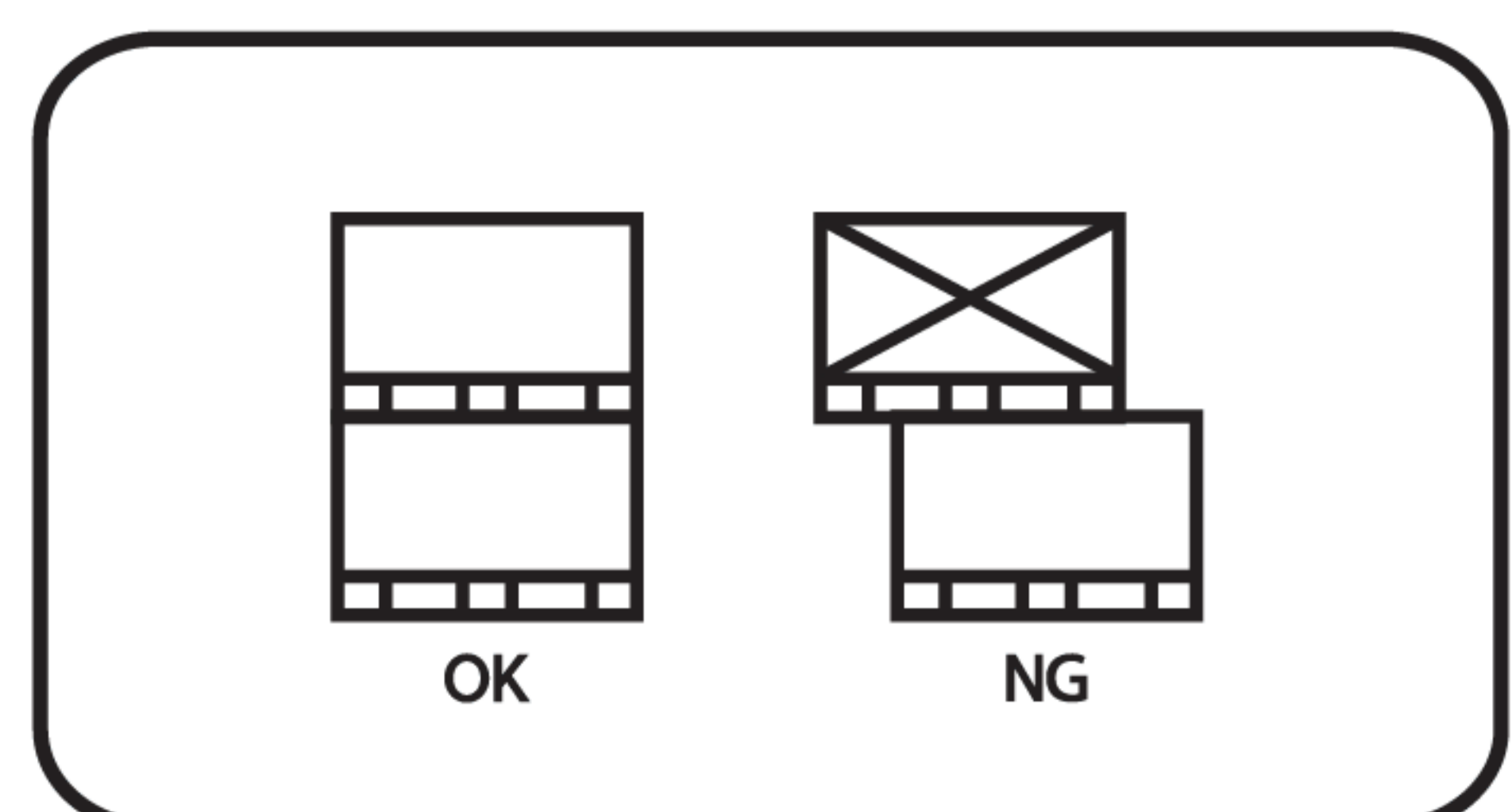
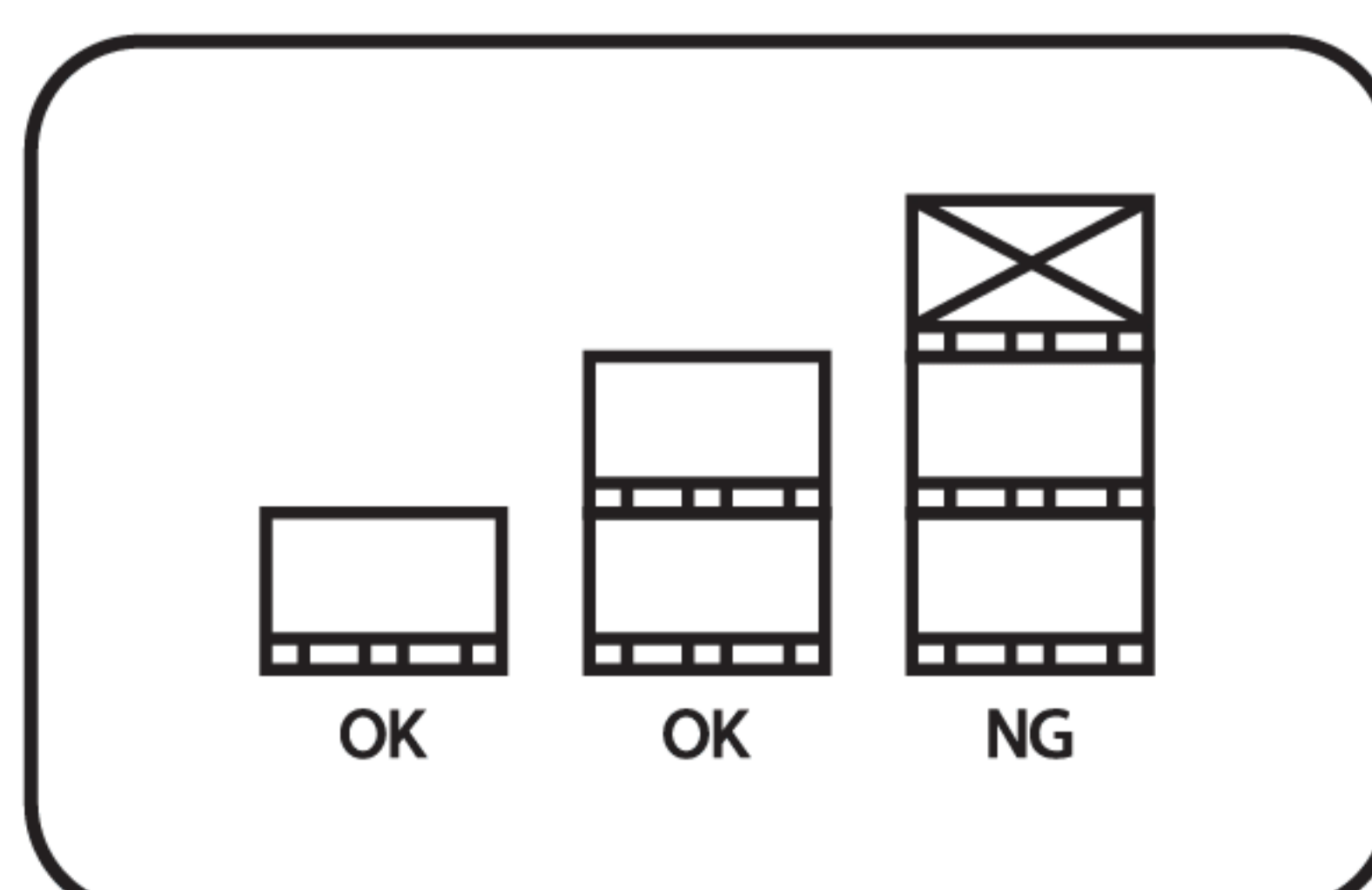

# Semicon Packaging Specifications

Category		Packaging	FCL(MT) With Pallet	
			20FT	40FT
Semicon	8720BK	Carton Box 650kg (CB650)	13	23.4
	8725BK	Same as 8720BK		
	8730BK			
	8735BK			
	8740BK			
	8745BK			
	8750BK	Same as 8720BK		
	8760BK			

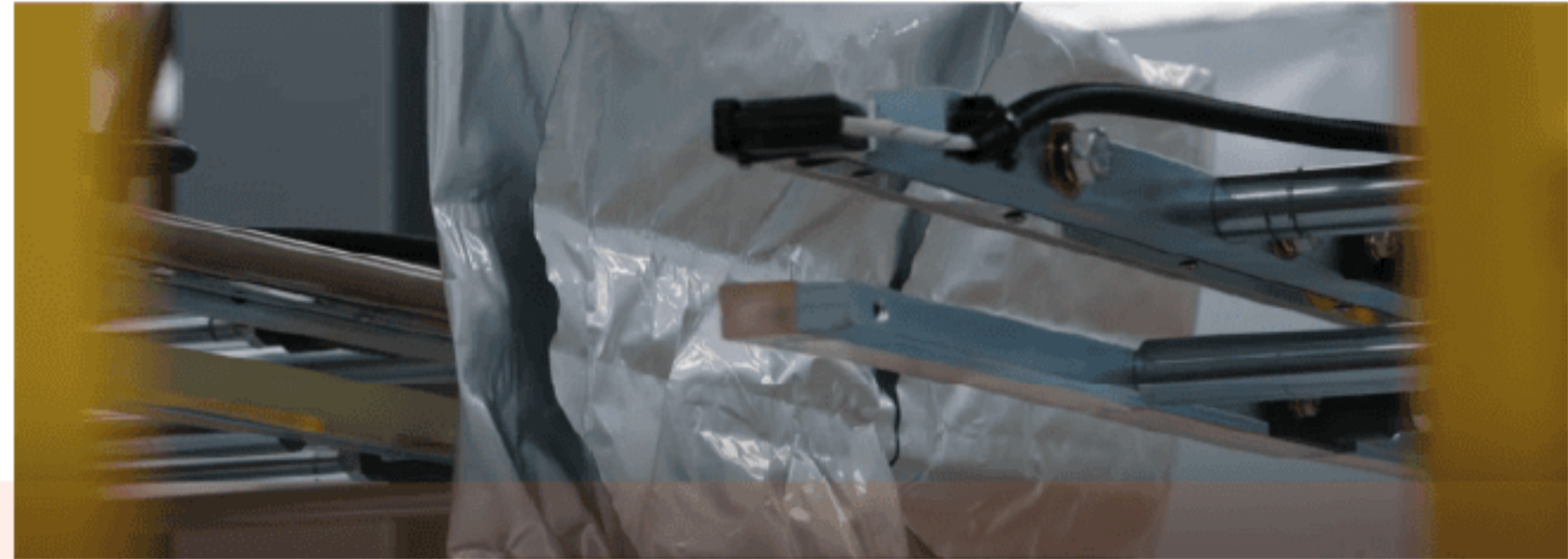

Aluminium Liner is applied to 8750BK and 8760BK to protect their electrical stability and cleanliness from moisture and oxygen

[Unit: mm]



650 kg Packaging

[Unit: mm]

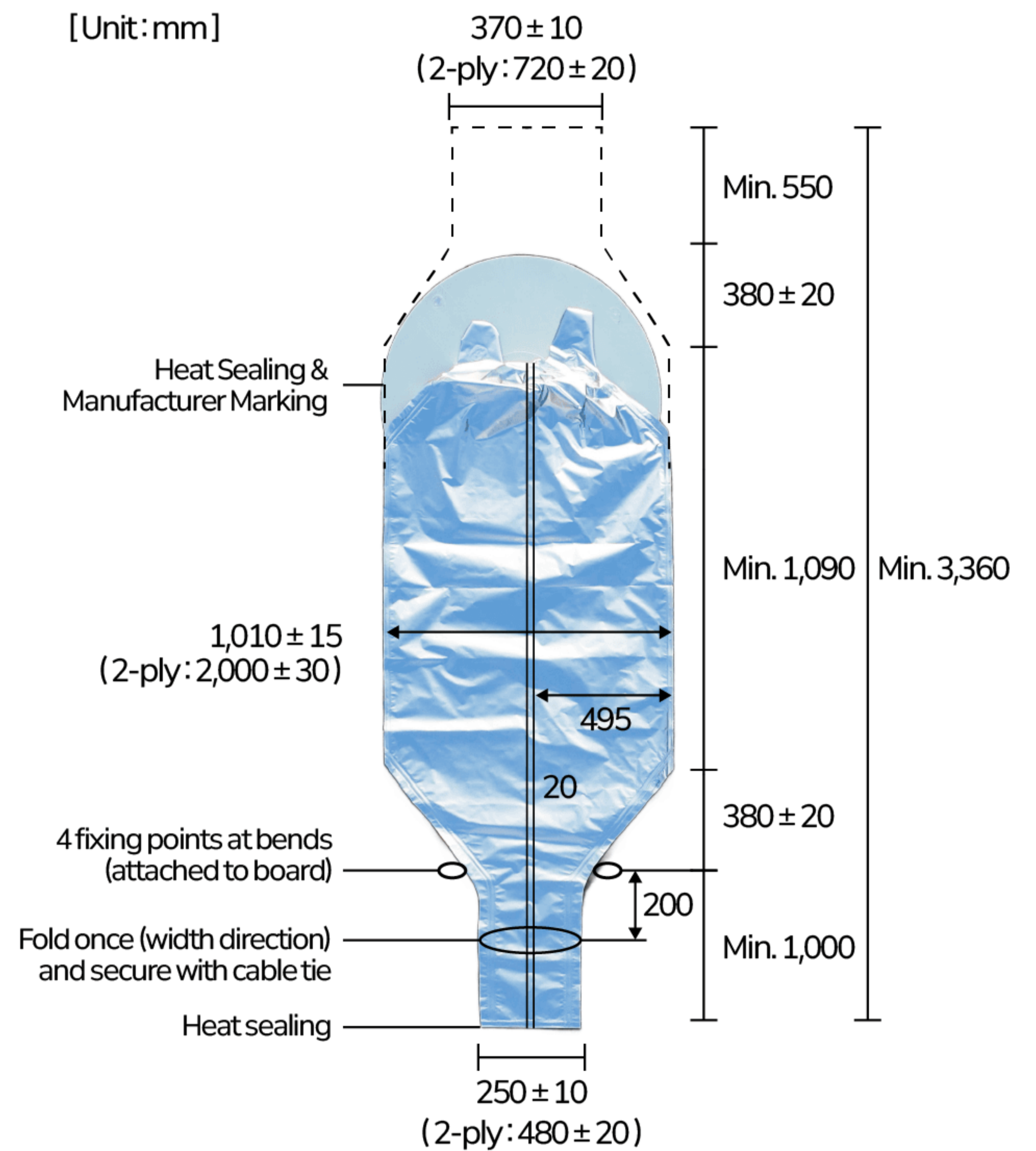

Match Liner Film

**Semicon Packaging :**  
Maximum stacking height of 3 units per pallet

FCL(MT) With Pallet	
20FT	40FT
13	23.4

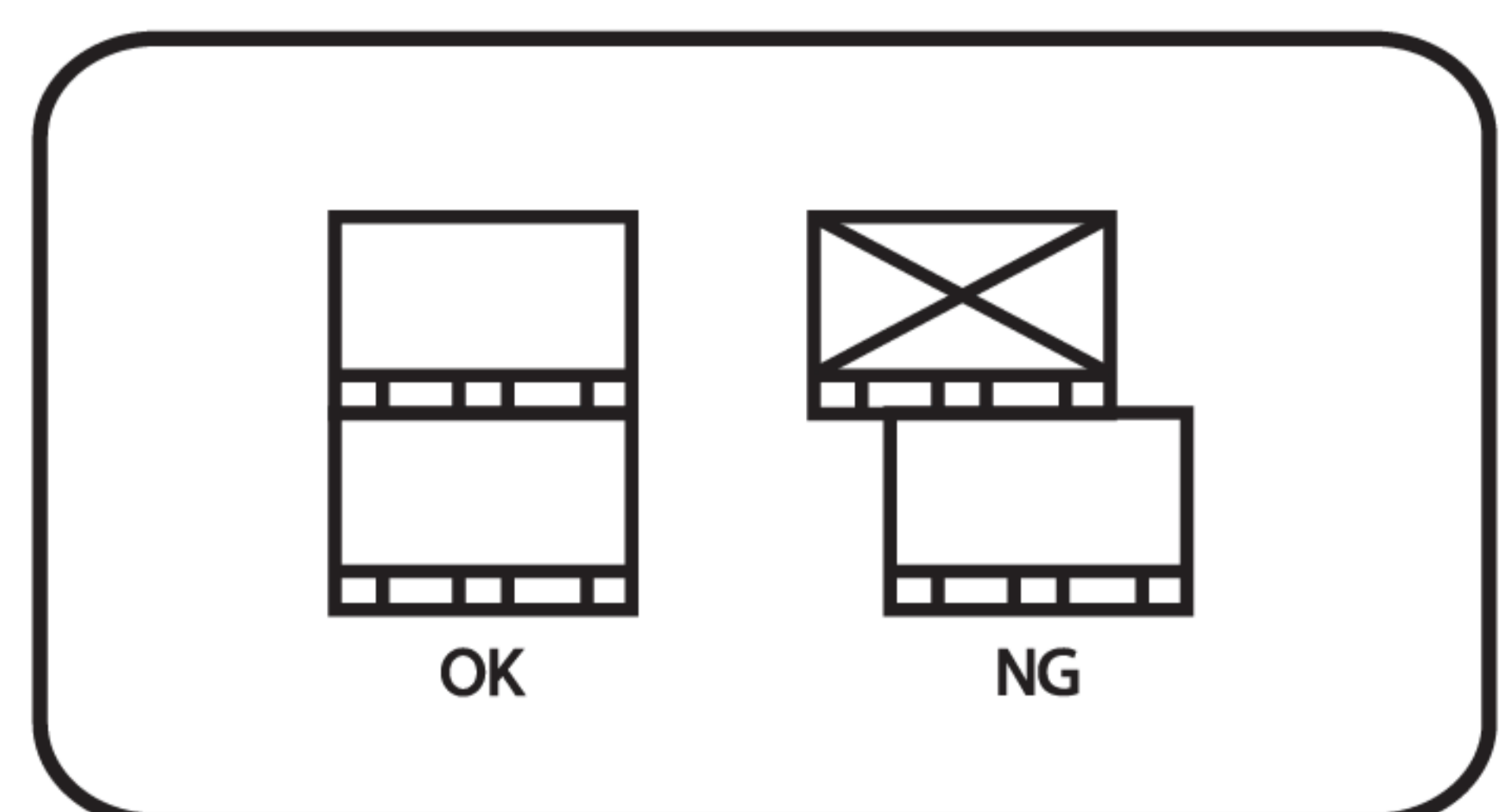
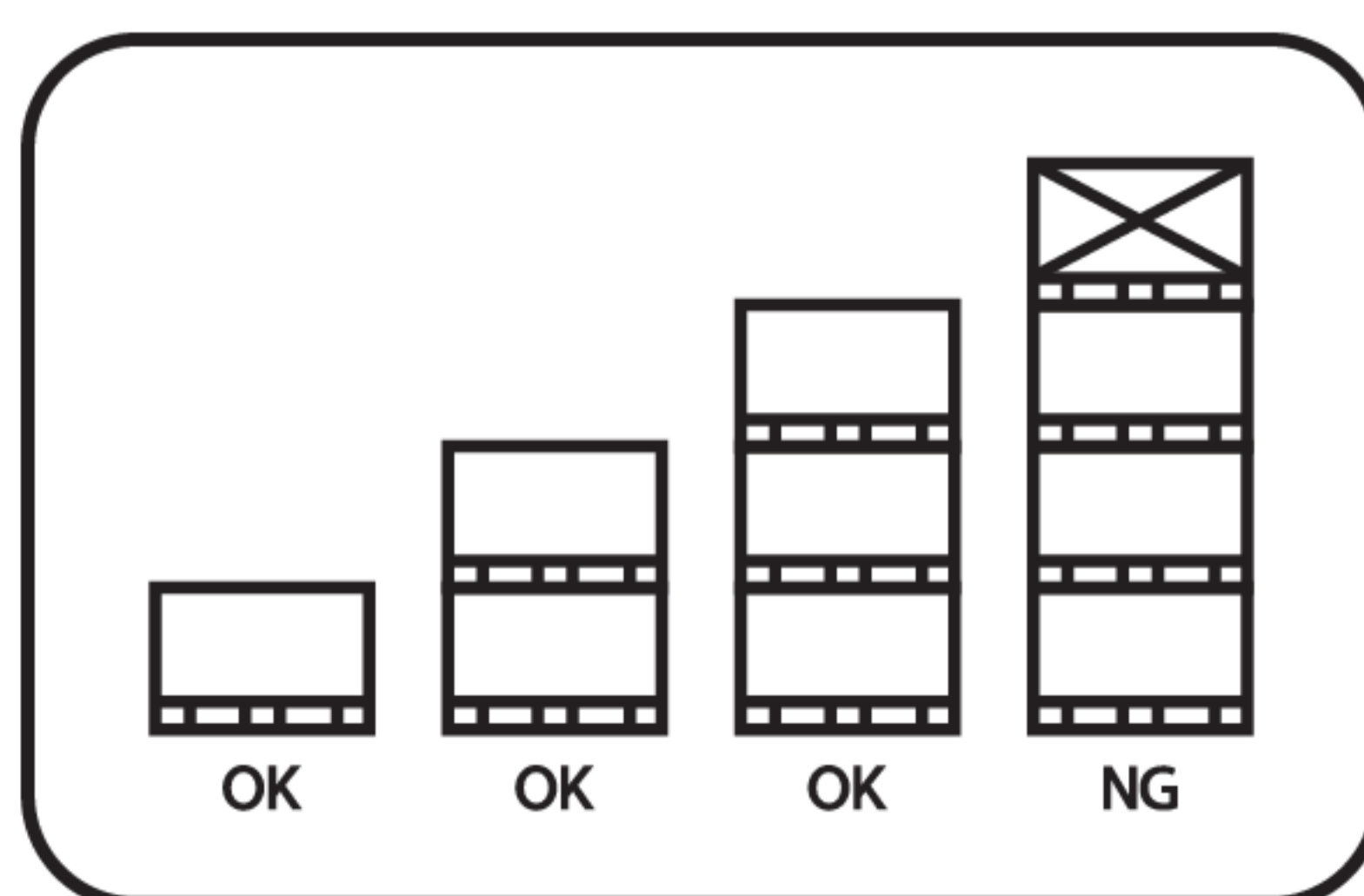

# Jacket Packaging Specifications

Category		Packaging	FCL(MT) With Pallet	
			20FT	40FT
Jacket	850BK	Flecon Bag 500kg (FB500)	10	22
		Carton Box 600kg (CB600)	12	23.4
		JID (25kg)	12	24
	8450BK	Carton Box 600kg (CB600)	12	23.4
		Flecon Bag 700kg (FB700)	14	22.4
		JID (25kg)	12	24
	8240BK	Carton Box 600kg (CB600)	12	23.4
		Flecon Bag 700kg (FB700)	14	22.4
		JID (25kg)	12	24
	8241BK	Carton Box 600kg (CB600)	12	23.4
		Flecon Bag 700kg (FB700)	14	22.4
		JID (25kg)	12	24

[Unit:mm]



600 kg Packaging

[Unit:mm]

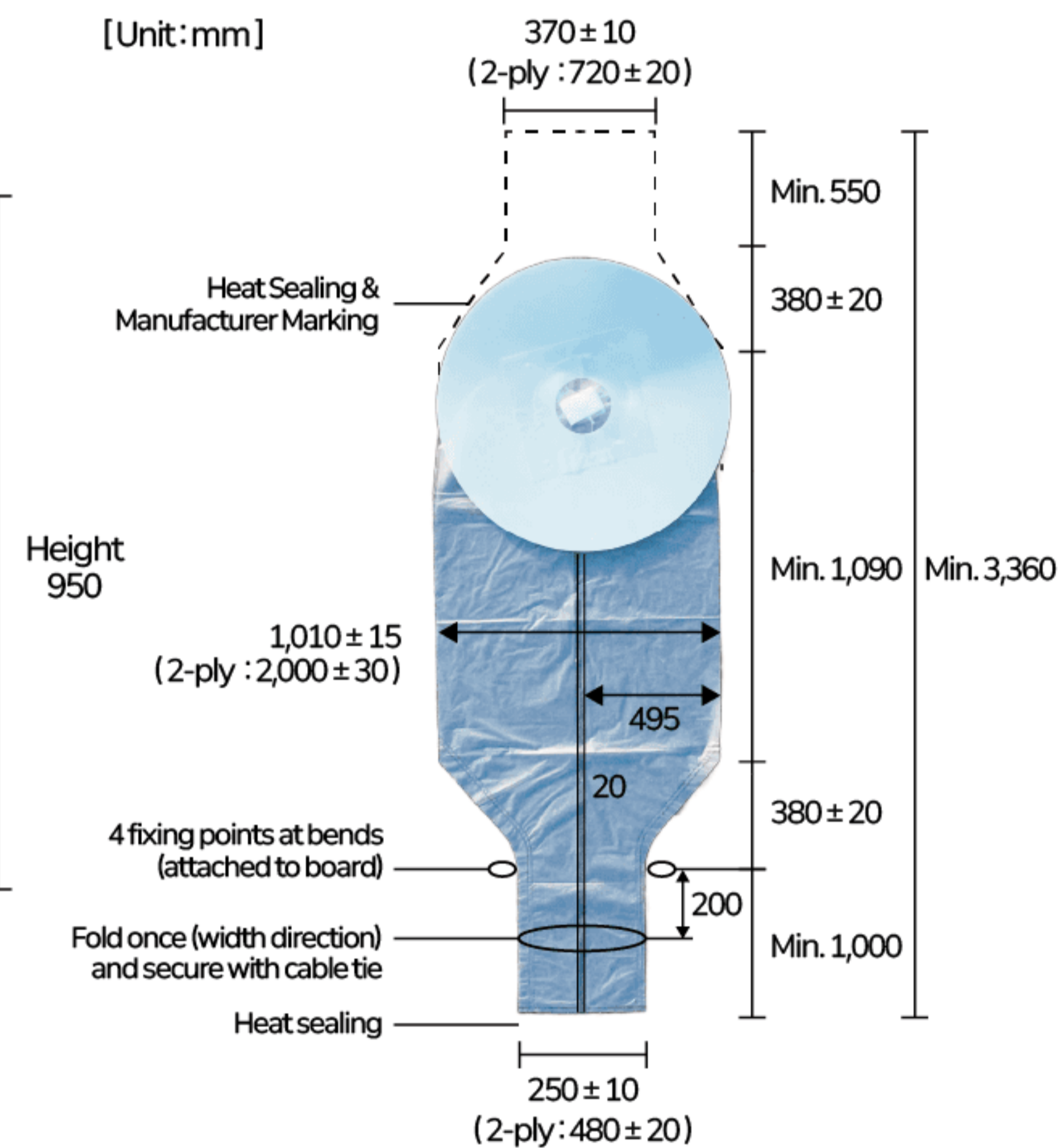

Match Liner Film



Match JID(25KG)



Flecon Bag 500/700kg

**Jacket Packaging :**  
Maximum stacking height of 3 units per pallet

Packaging	FCL(MT) With Pallet	
	20FT	40FT
JID (25kg)	12	24
Carton Box 600kg (CB600)	12	23.4
Flecon Bag 700kg (FB700)	14	22.4

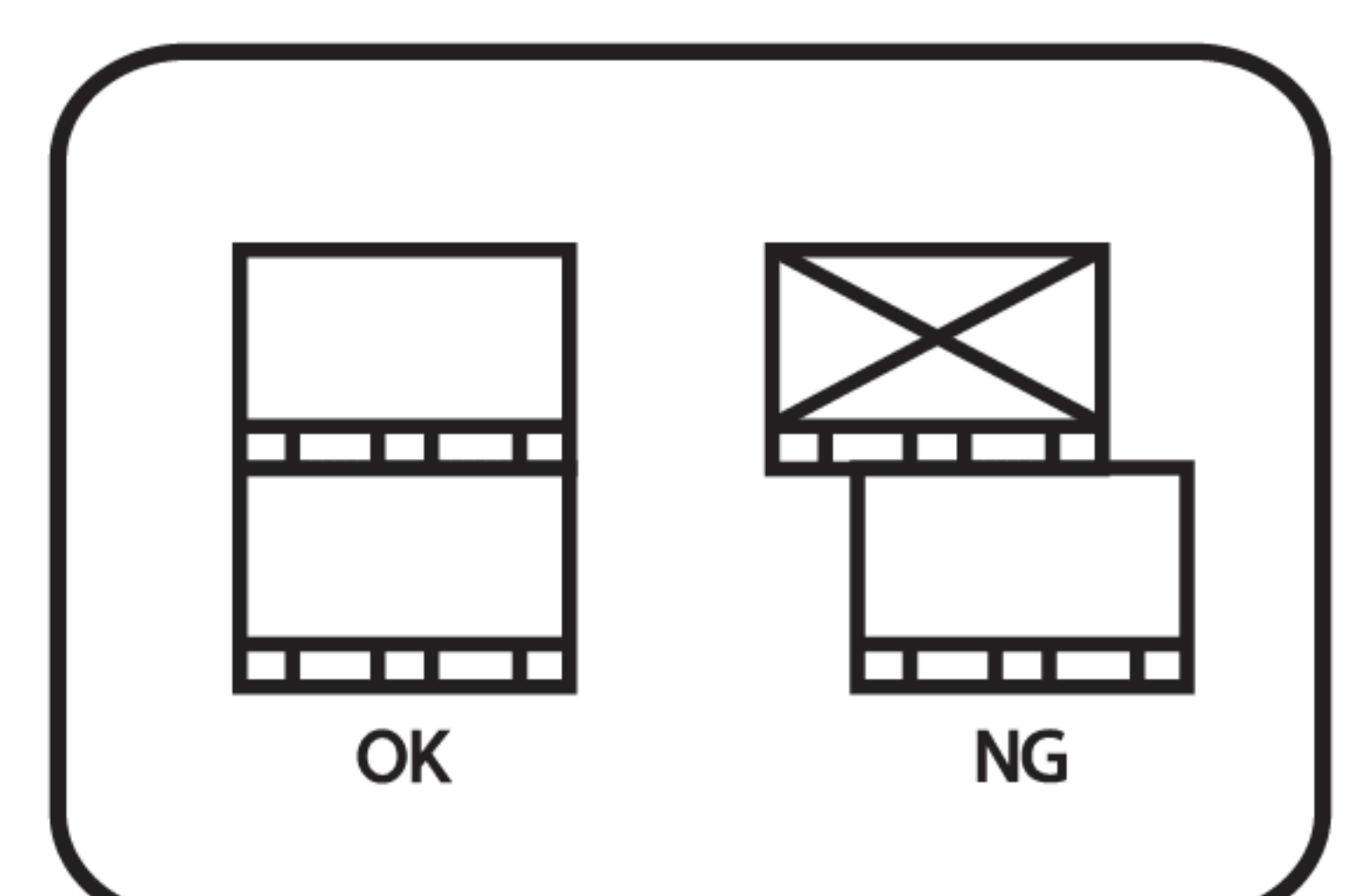
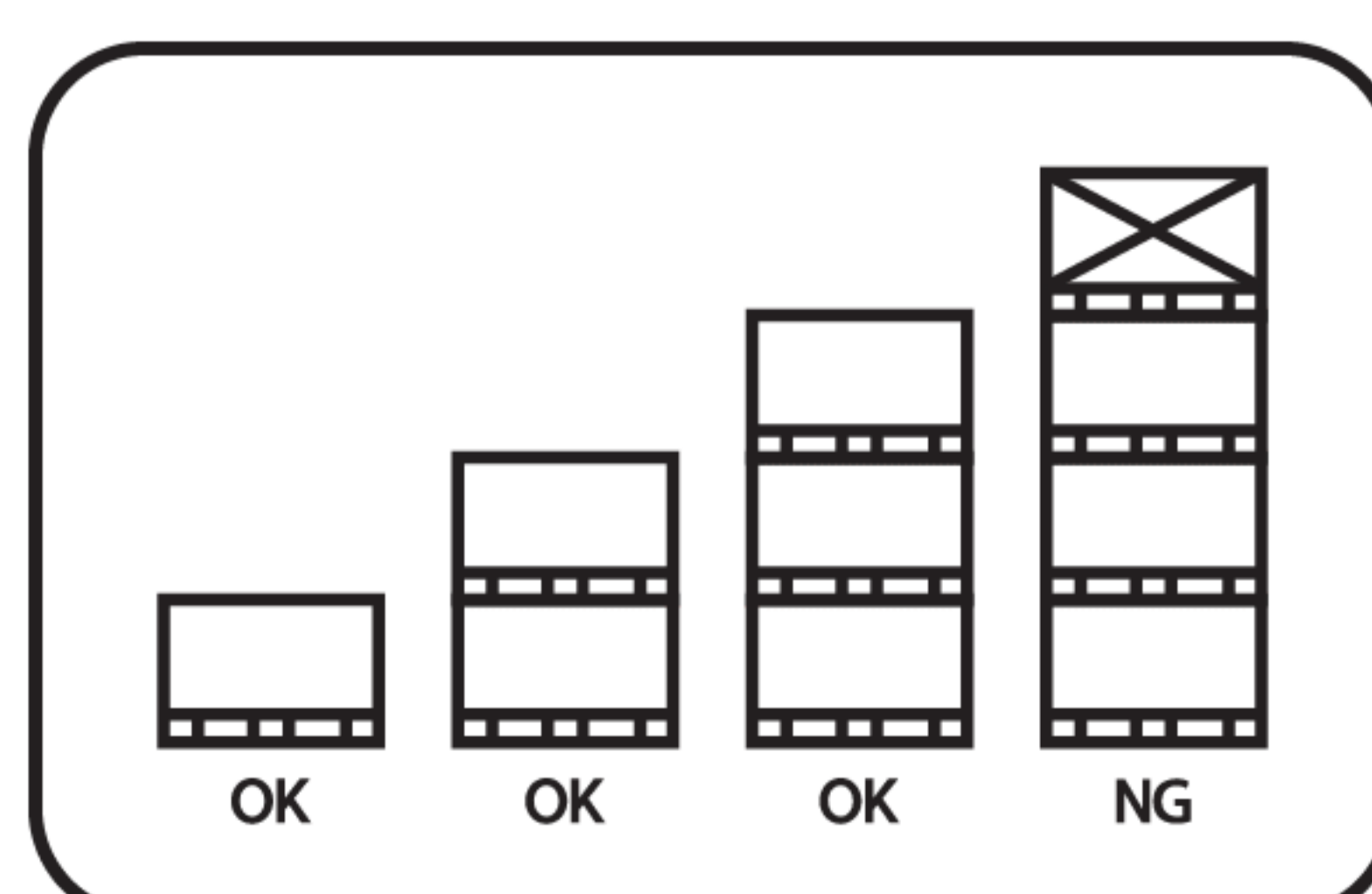

# OTHER INFORMATION



WIRE & CABLE  
**WIRE & CABLE  
COMPOUND**

NET WT. 25kg  
MADE IN KOREA

 **한화솔루션**  
Hanwha Solutions

CLBA 8450BK  
YW2018252  
25KG

**POLYETHYLENE**

폴리에틸렌

NET WT. 700kg  
MADE IN KOREA

 **한화솔루션**  
Hanwha Solutions

Bag Maker  
YW

# Flecon Bag Information

## Optimized Bulk Packaging for Cable Compounds

Our disposable Flecon Bag is engineered to provide safe, clean, and efficient bulk packaging for cable compound products. Designed according to HSY-R-67372 specifications, it ensures excellent durability, contamination-free handling, and stable stacking during storage and transportation.

- High-strength woven fabric for enhanced load stability
- Dust-tight, contamination-free structure suitable for ultra-clean compounds
- Optimized dimensions for efficient container loading and warehouse handling
- Single-use hygienic design preventing material carryover
- Compatible with FIBCs (Flexible Intermediate Bulk Containers) handling systems
- Provides reliable protection during long-distance export shipments

This Flecon Bag delivers the balance of durability, cleanliness, and operational efficiency required for global cable compound logistics.



## BAG SPECIFICATION

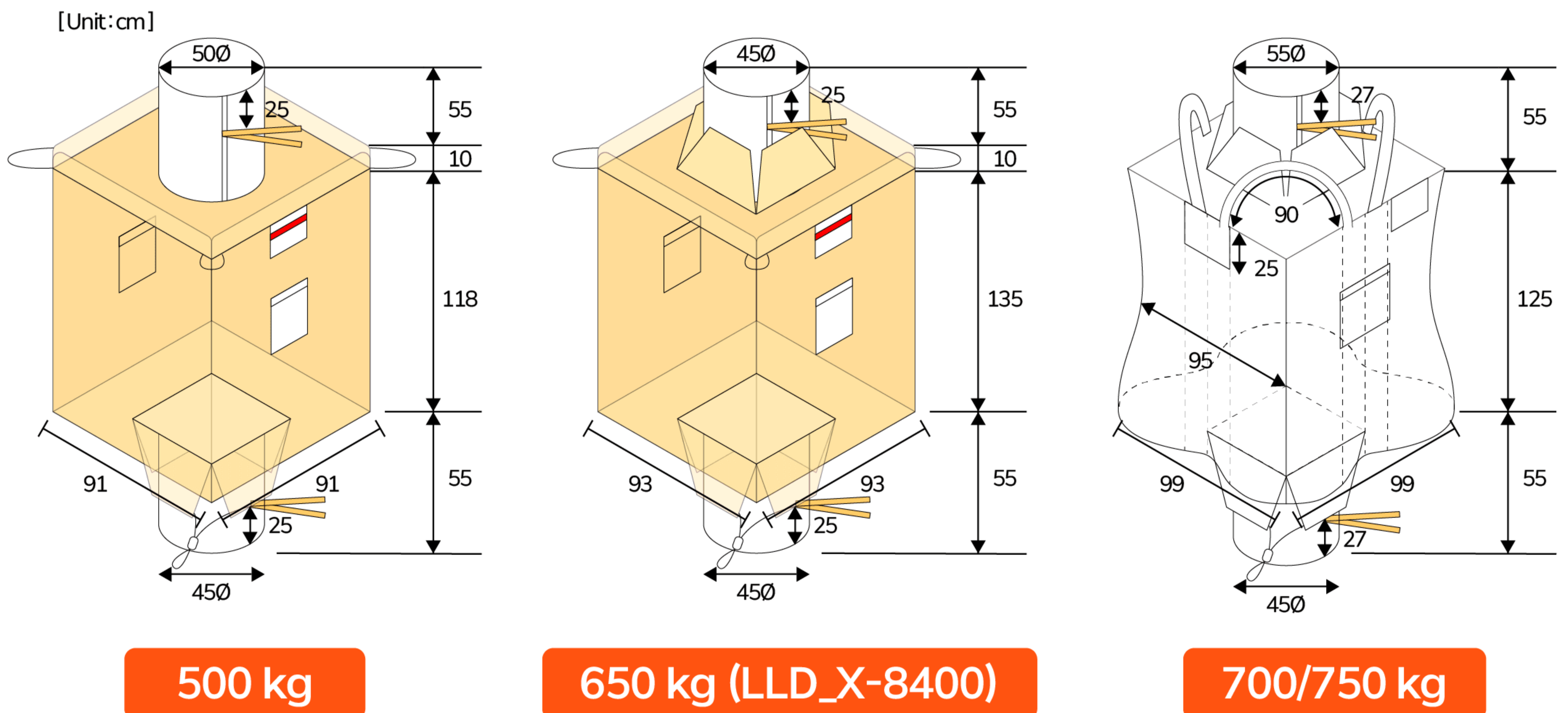

# JID(PP Paper Bag) 25kg

## Standard Packaging Solution for 25kg Cable Compounds

The JID (25kg) PP Paper Bag is a reliable small-package format designed to safely store and transport cable compound products.

- High-strength PP + paper composite material provides excellent tear and impact resistance
- Enhanced moisture and contamination protection, suitable for long-term storage
- Optimized 25kg unit packaging for efficient palletizing and handling
- Stable dimensions and sealing structure compatible with automated filling lines
- Superior stacking stability minimizes deformation during transportation

A lightweight, safe, and dependable packaging option for 25kg cable compound products.

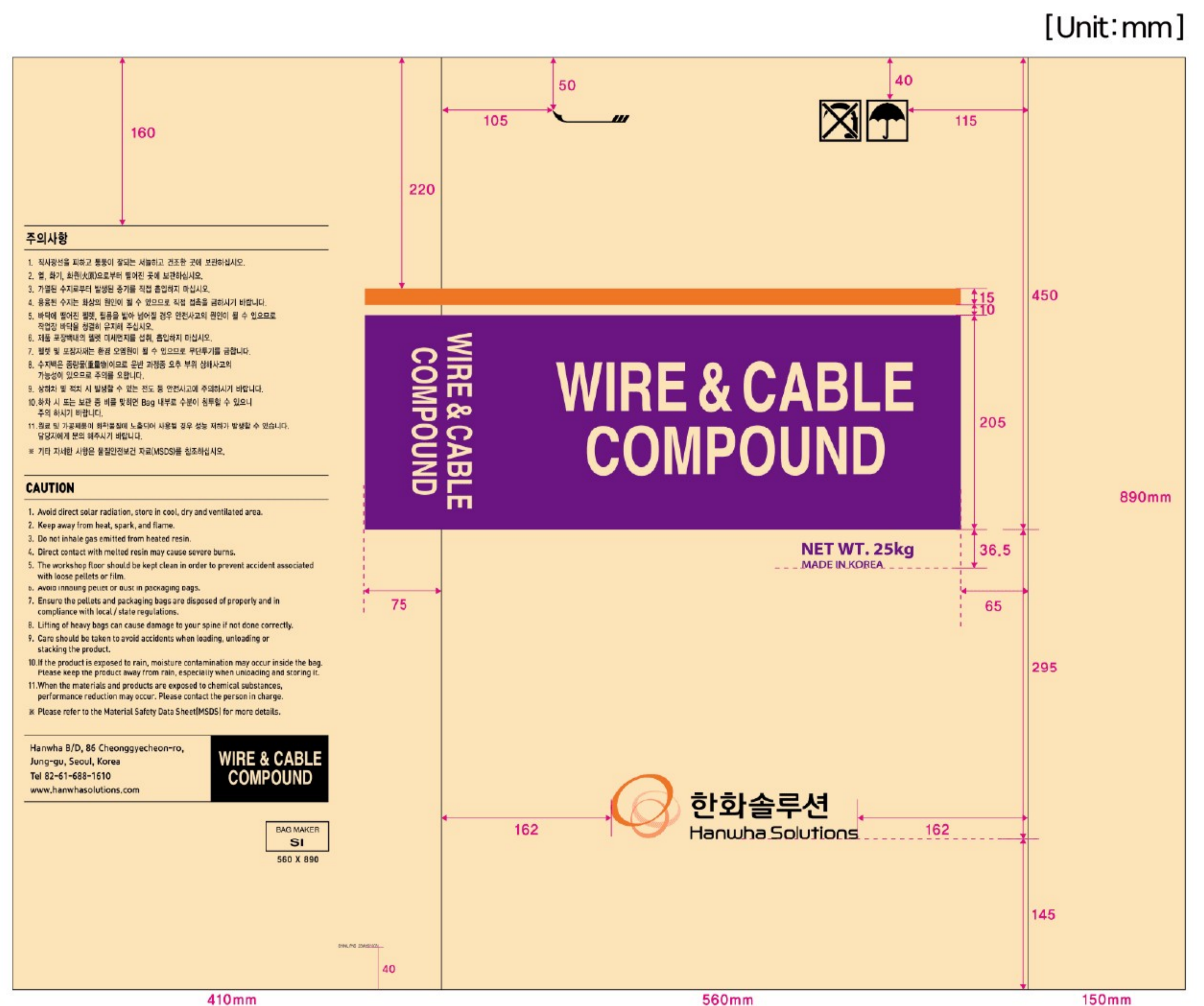

## BAG SPECIFICATION

# FFS(Roll Bag) 25kg

## 25kg Film Packaging Solution Optimized for Automatic Filling Lines

The FFS (25kg) Roll Bag is a film-based packaging system designed for automatic filling and sealing (FFS), enabling fast, efficient, and stable packaging of cable compound products.

- High-durability PE film with excellent resistance to impact and abrasion
- Precisely controlled thickness and dimensions for seamless compatibility with automated packaging lines
- Moisture- and dust-blocking structure to maintain product cleanliness
- Supplied in roll form for continuous, high-speed production
- Printable surface for enhanced product identification
- Outstanding stability to minimize deformation during storage and transportation

The FFS Roll Bag delivers both production efficiency and packaging reliability, making it a trusted solution for 25kg cable compound products.

### LLDPE

### HDPE

[Unit: mm]

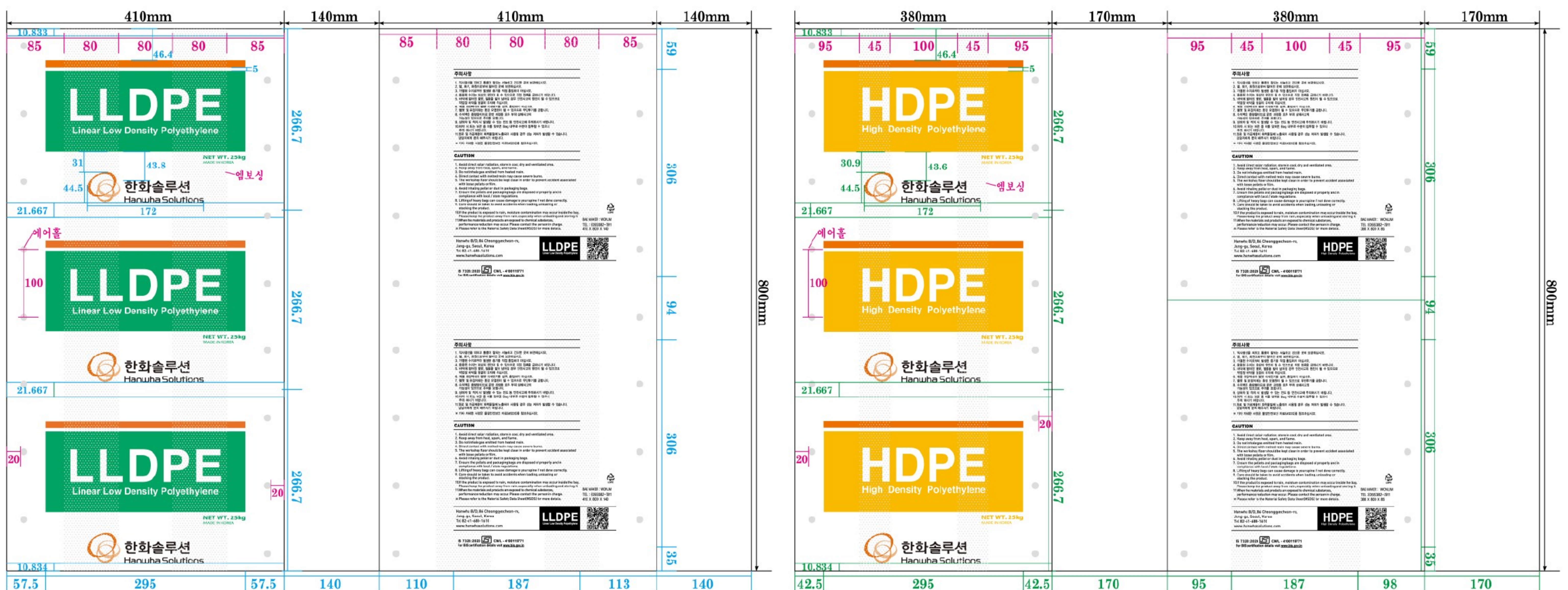

## BAG SPECIFICATION

# Wooden Pallet

## Optimized Wooden Pallets for Cable Compounds

Our wooden pallets provide stable and reliable support for both domestic and export packaging. Engineered with outstanding quality, the pallets feature smooth, non-sharp edges that enhance handling safety and help prevent damage to packaging materials during transportation and storage.

Made from well-dried timber with a maximum moisture content of 20%, they effectively resist moisture and mold. The pallets are also heat-treated in accordance with ISPM-15 standards to prevent insect contamination and ensure full compliance with international shipping requirements.

- High-quality timber for durability and load stability
- Smooth, non-sharp edges for safer handling and reduced damage risk
- Moisture-controlled design (Max. 20%) to minimize mold risk
- ISPM-15 heat treatment for pest prevention and export compliance
- Secure stacking and efficient handling
- Suitable for standard and B/U packaging

This optimized wooden pallet solution ensures durability, cleanliness, and logistics efficiency for global cable compound packaging.



Category	Unit	Carton Box			
		Jacket		XLPE / Semicon	
		TYPE - (A)	TYPE - (B)	TYPE - (C)	TYPE - (D)
Moisture Content	%	Max. 20	Max. 20	Max. 20	Max. 20
Width	mm	1,140±5	1,140±5	1,140±5	1,140±5
Depth	mm	1,110±5	1,140±5	1,100±5	1,140±5
Height	mm	150±3	140±3	150±3	
Pallet Width	mm	90/120 ± 3			
Deck Thickness	mm	MIN. 18			
Number of Top Deck Boards	EA	4(Width 90mm), 3(Width 120mm)			
Number of Bottom Deck Boards	EA	6(Width 90mm), 5(Width 120mm)			
Block Size / Quantity	mm / EA	120 x 90 / 12			
Block Height / Quantity	mm / EA	78 / 12	68 / 12	78 / 12	
Nail Size / Quantity	mm / EA	50 / 2 (Square timber 4 pcs)			
Fork Entry	-	4 directions	4 directions	4 directions	4 directions
Application	-	Standard packing		B/U packing	
		600kg		550 / 650 / 1,000kg	

# Wooden Pallet

- Wooden Pallet Drawing ( A Type / B Type )

Front View

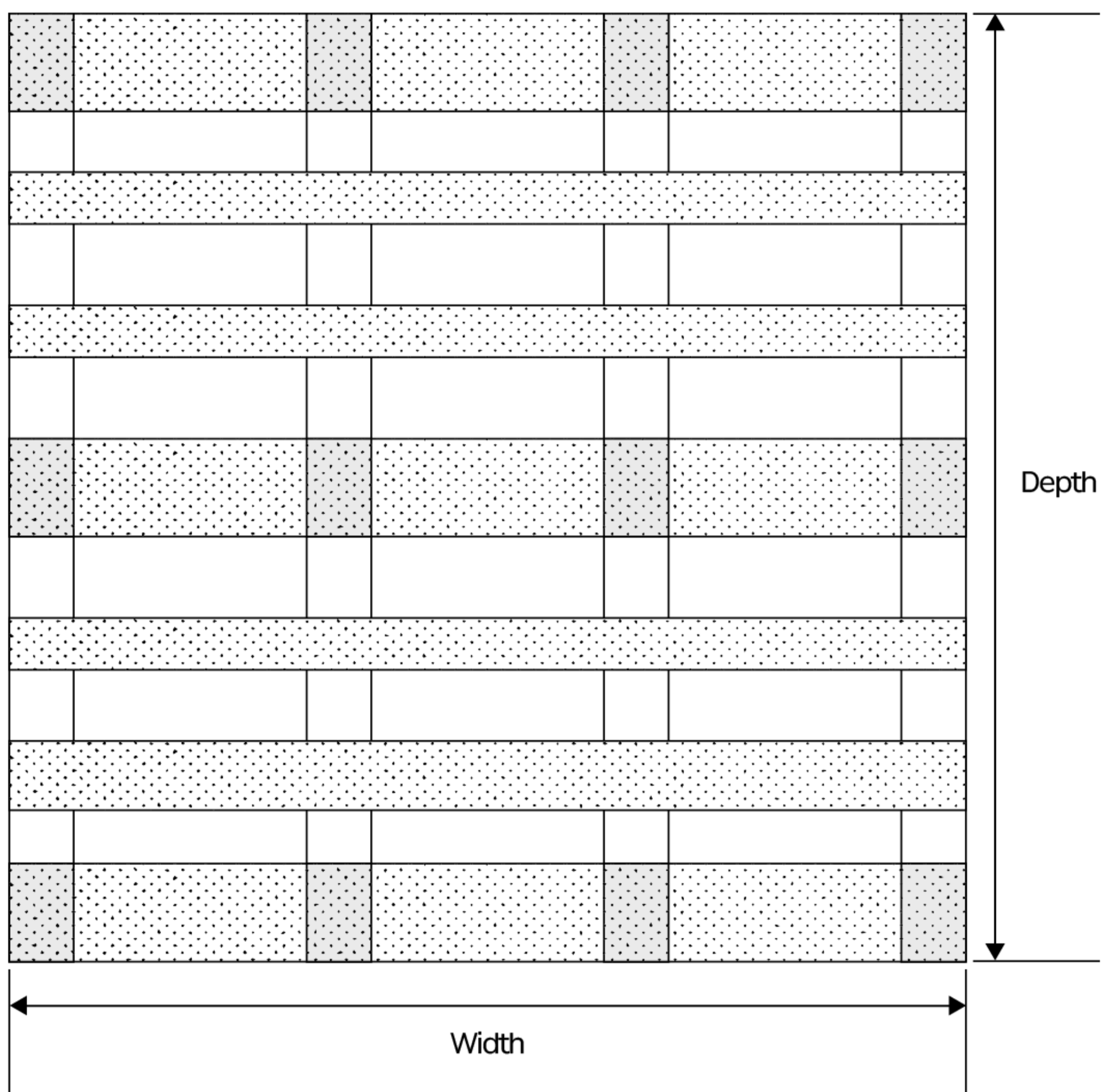

Side View

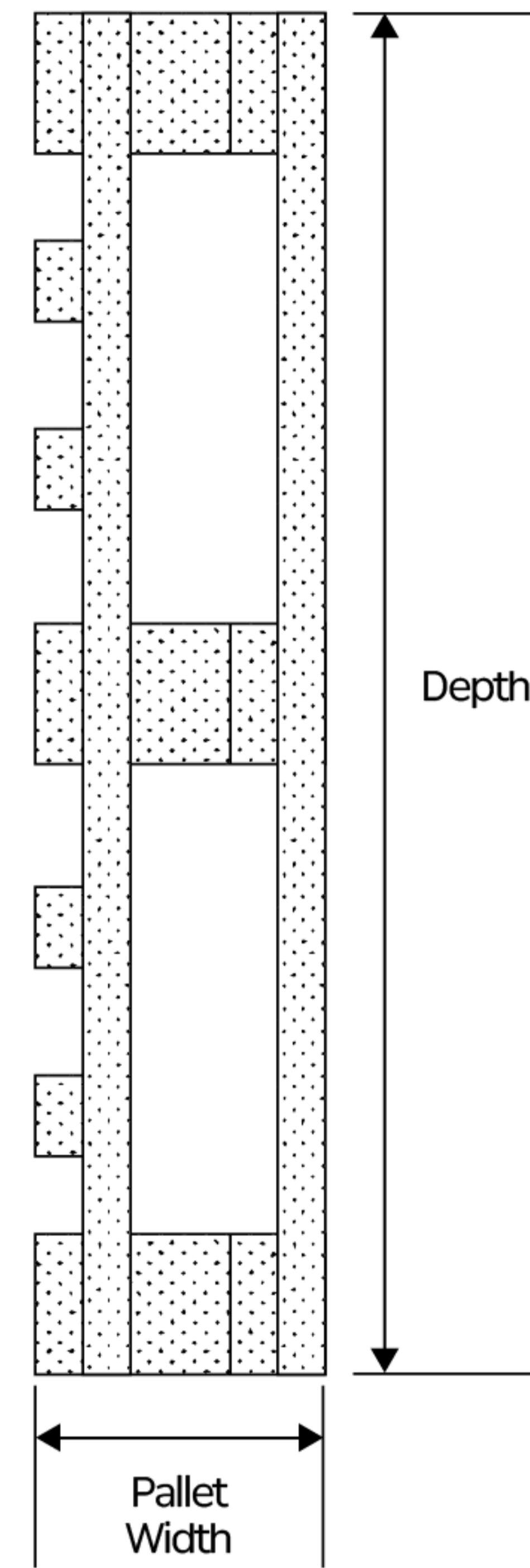

Rear View

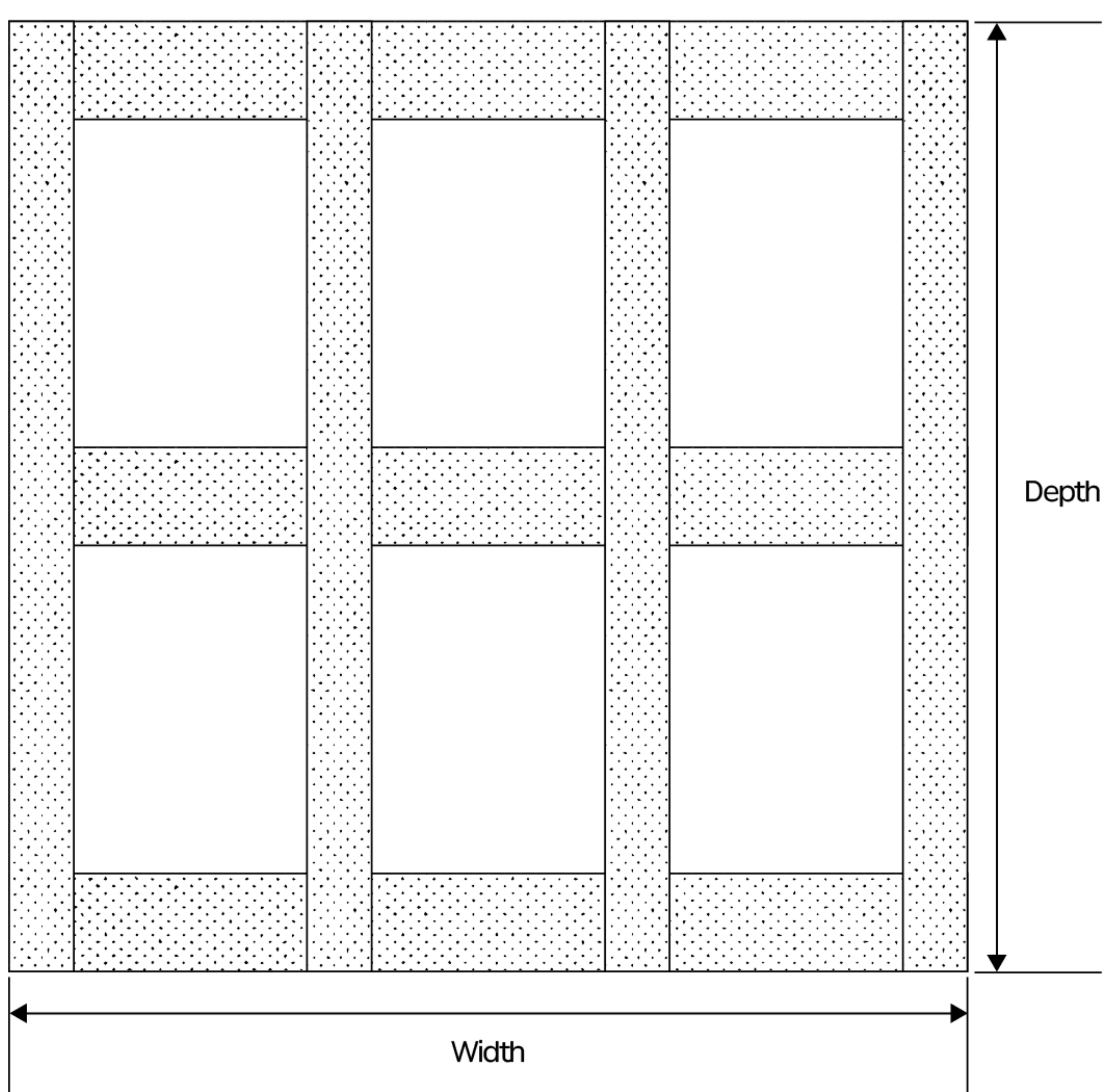

Side View

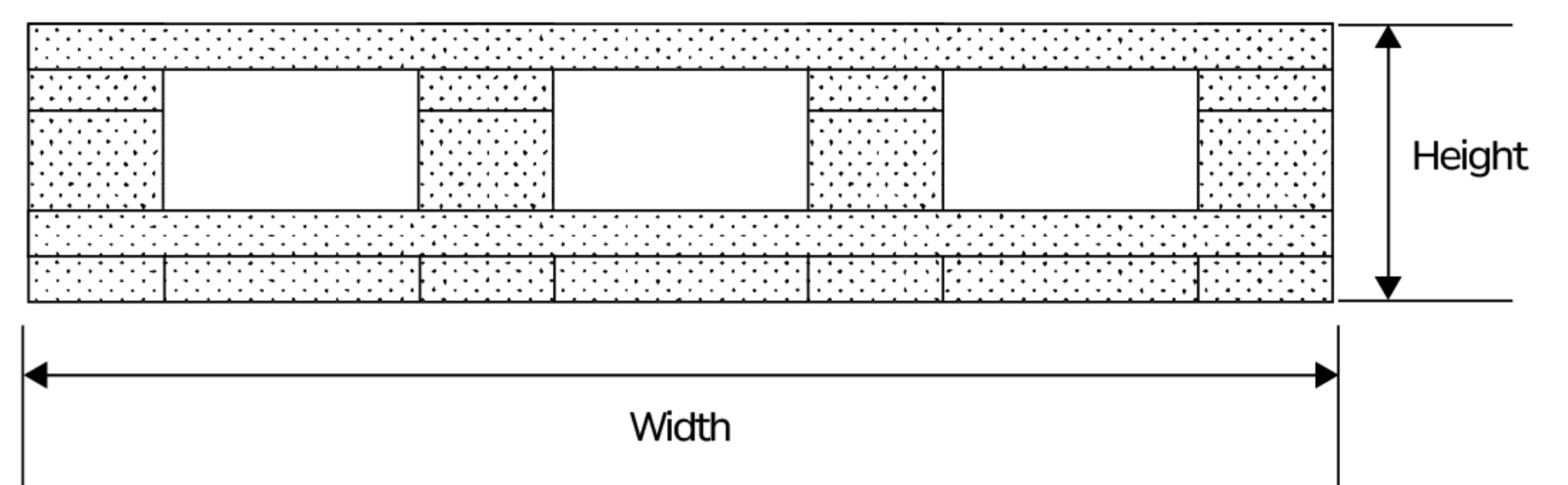

# Wooden Pallet

- Wooden Pallet Drawing ( C Type )

Front View

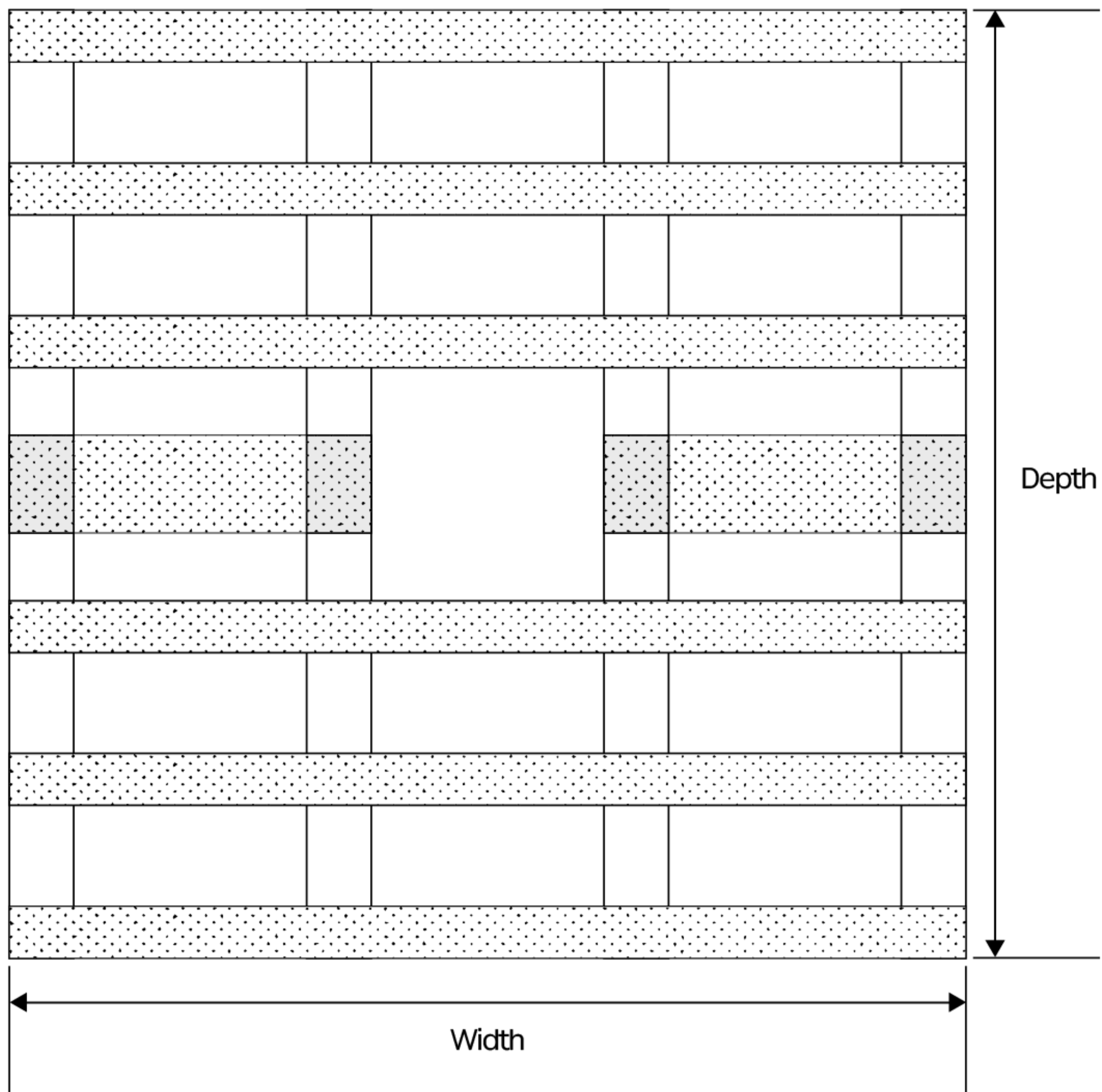

Side View

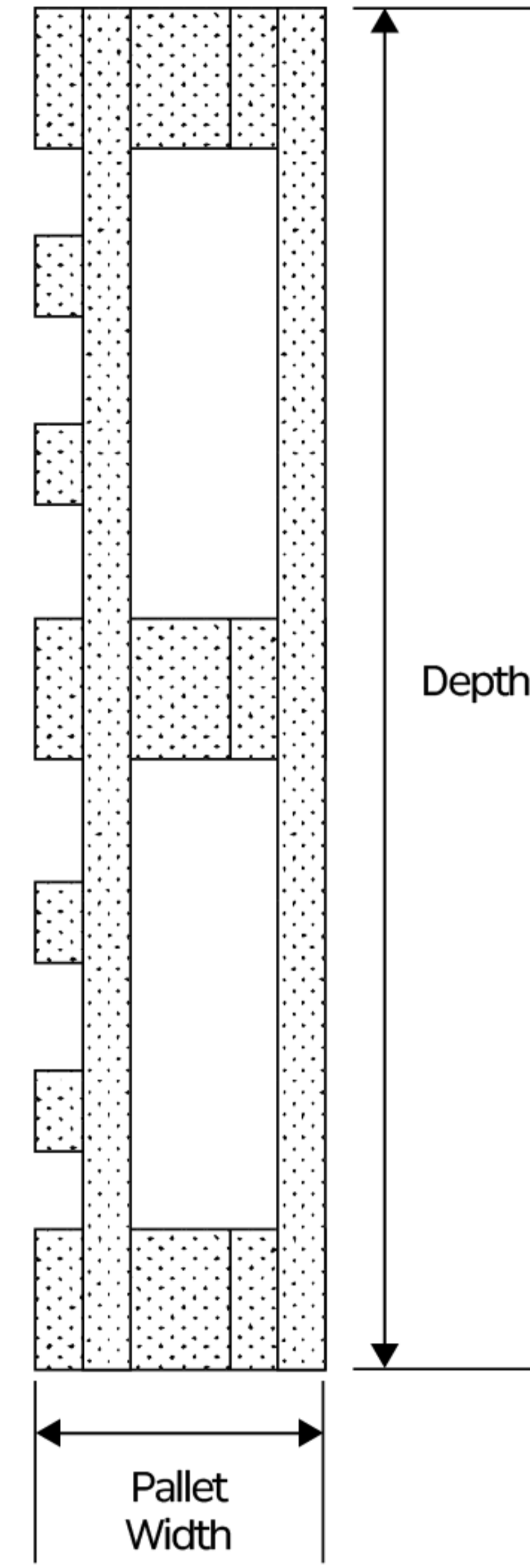

Rear View

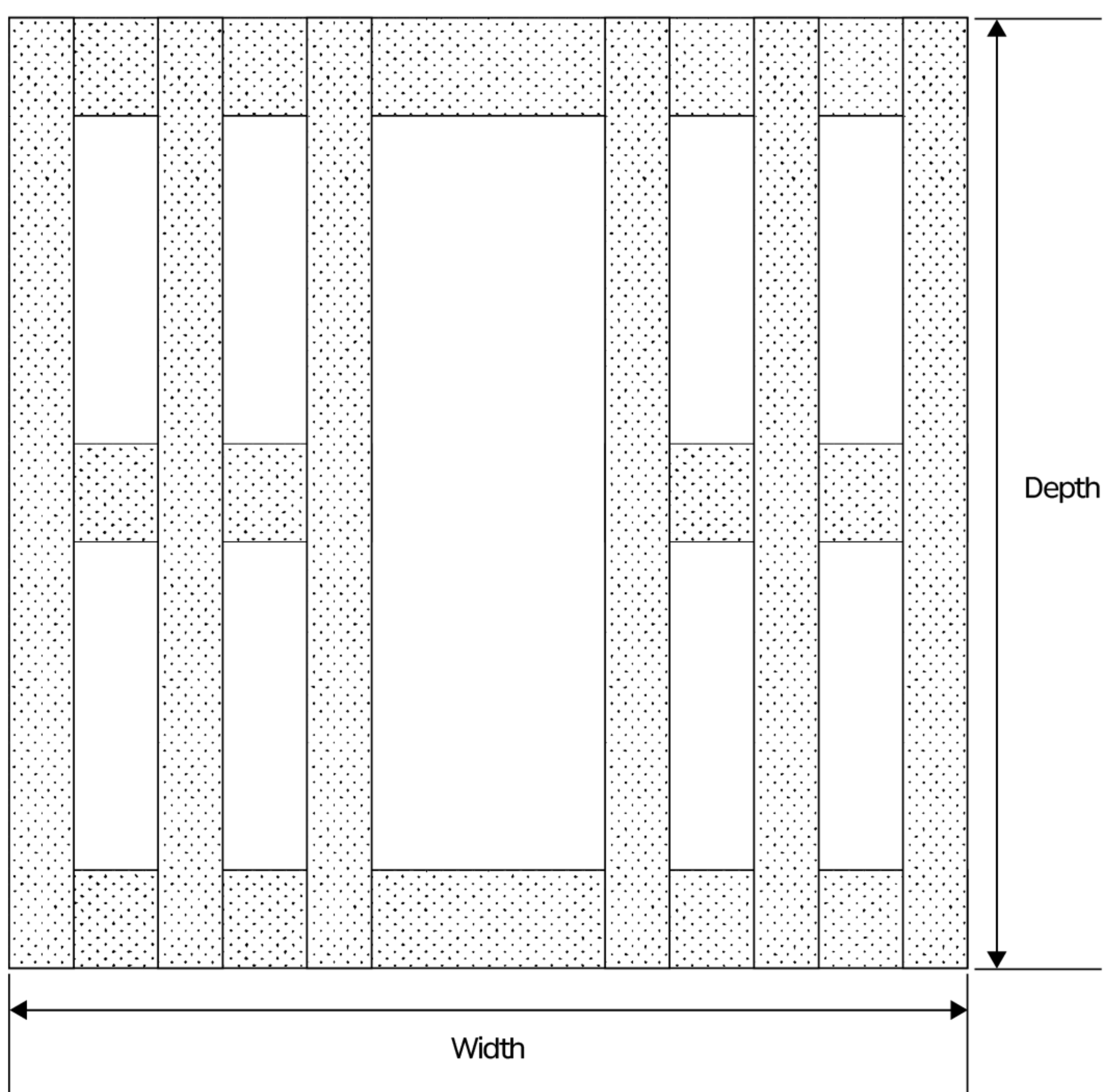

Side View

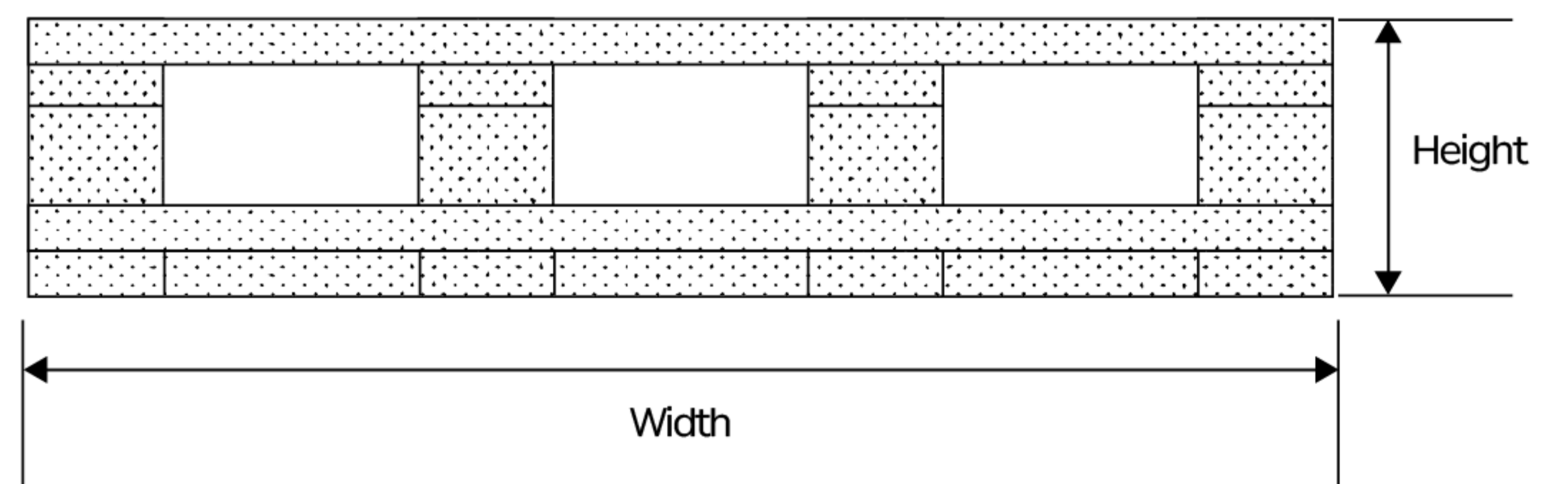

# Wooden Pallet

- Wooden Pallet Drawing ( D Type )

Front View

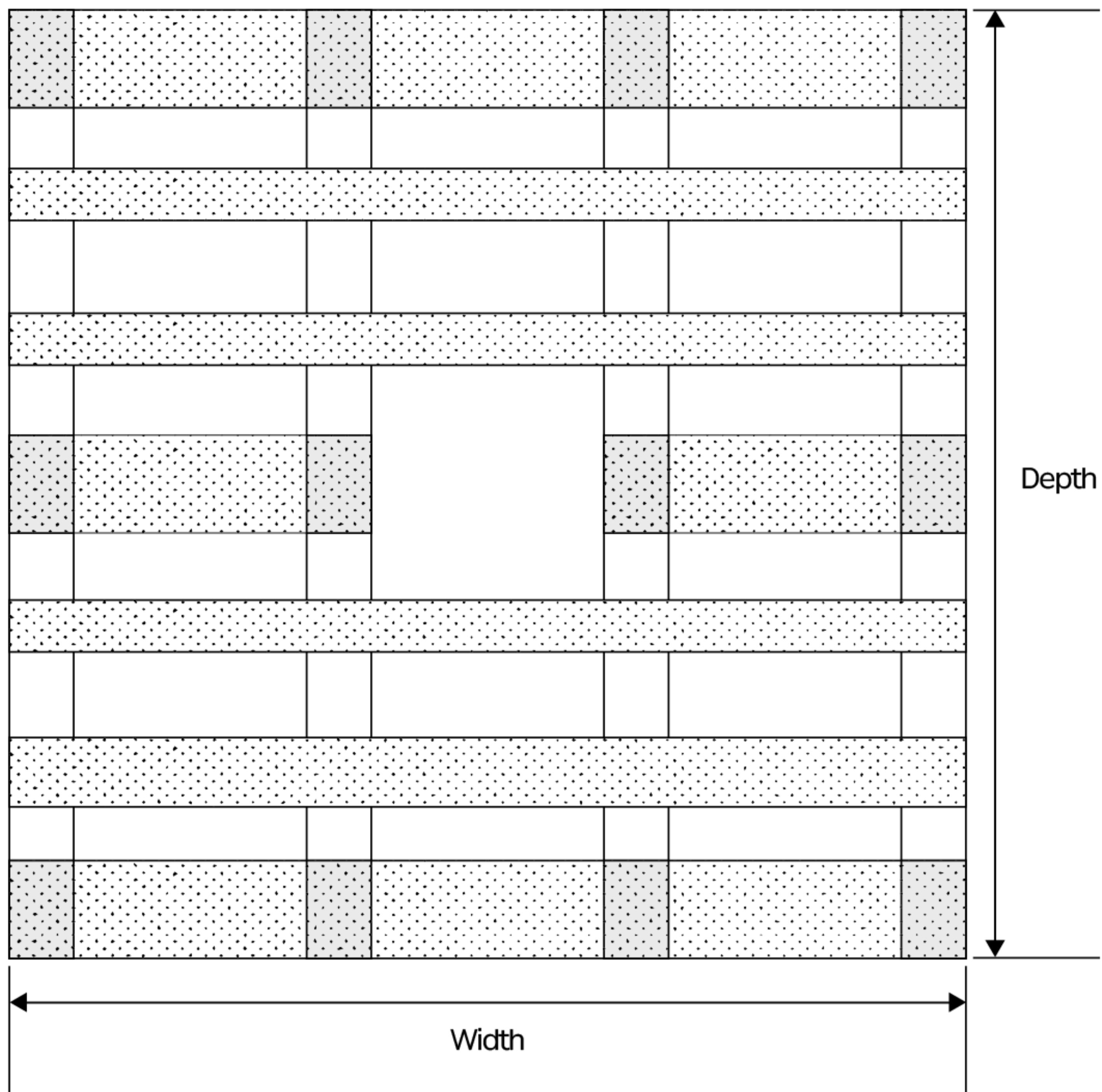

Side View

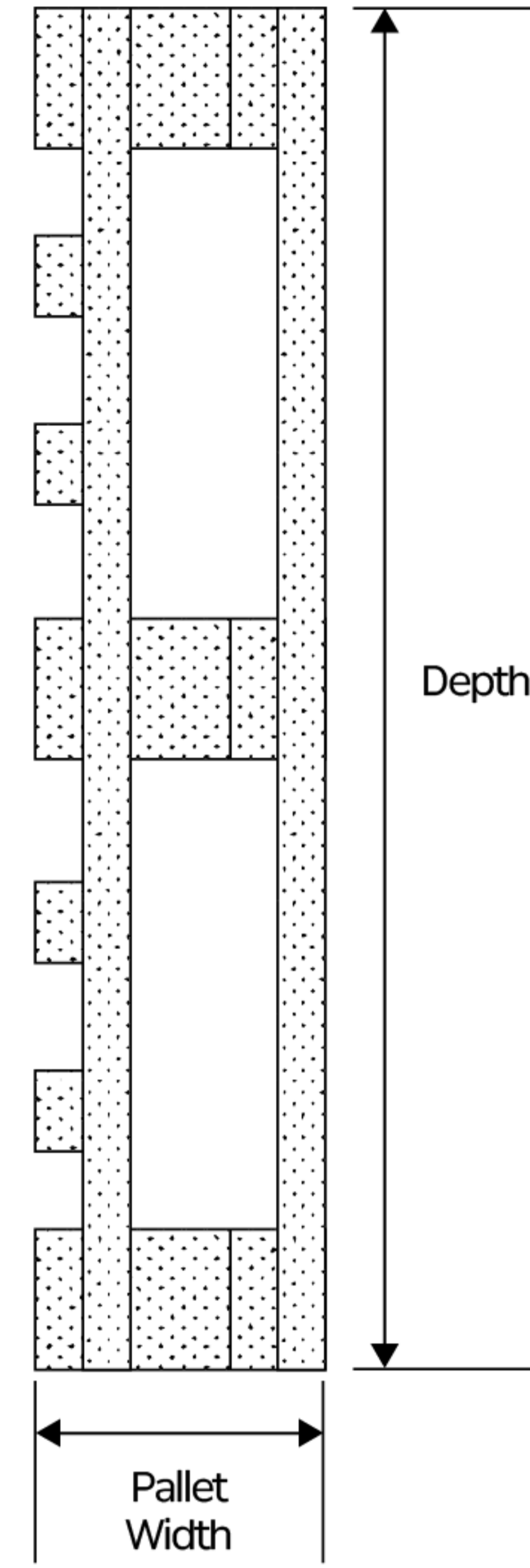

Rear View

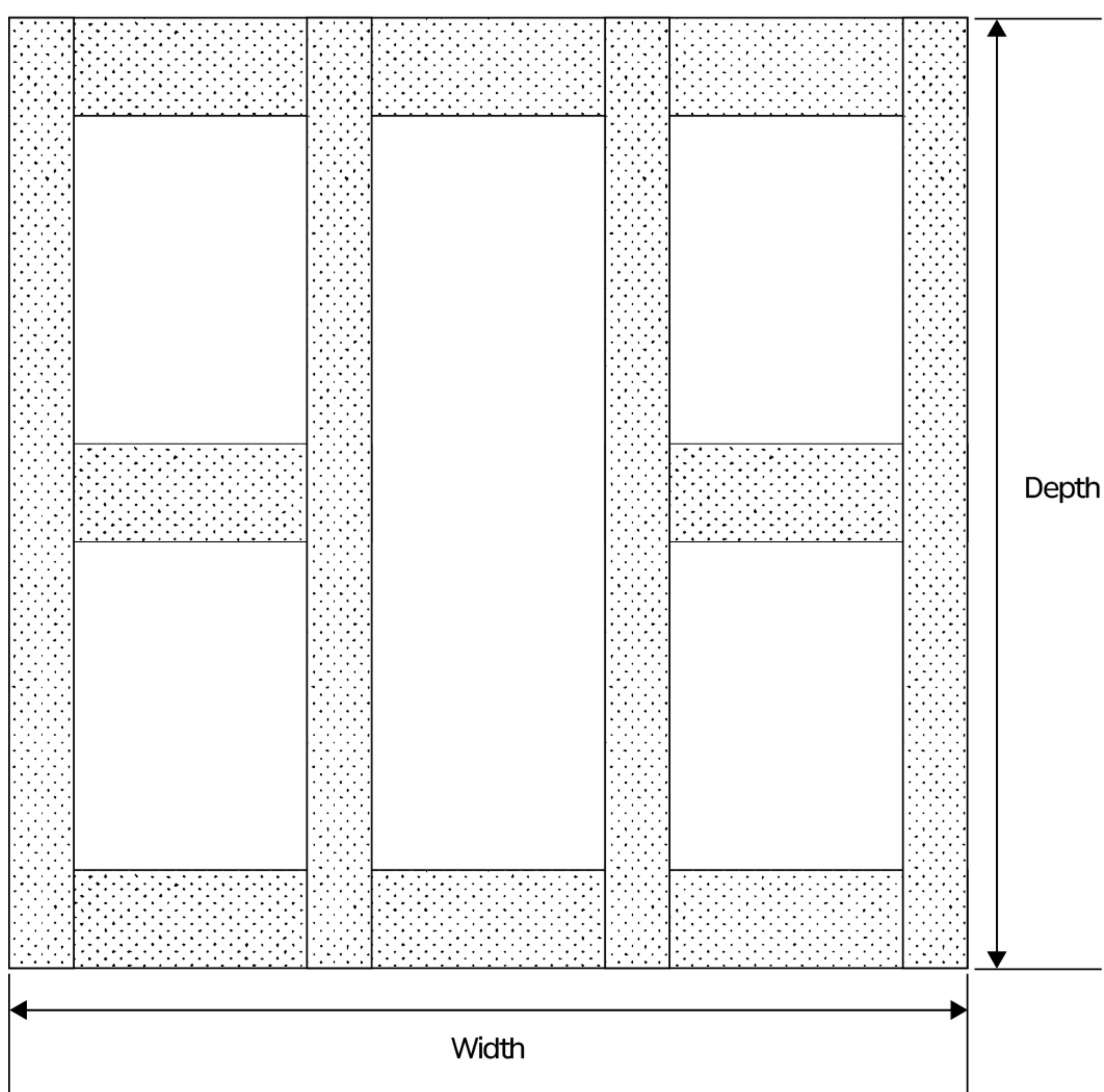

Side View

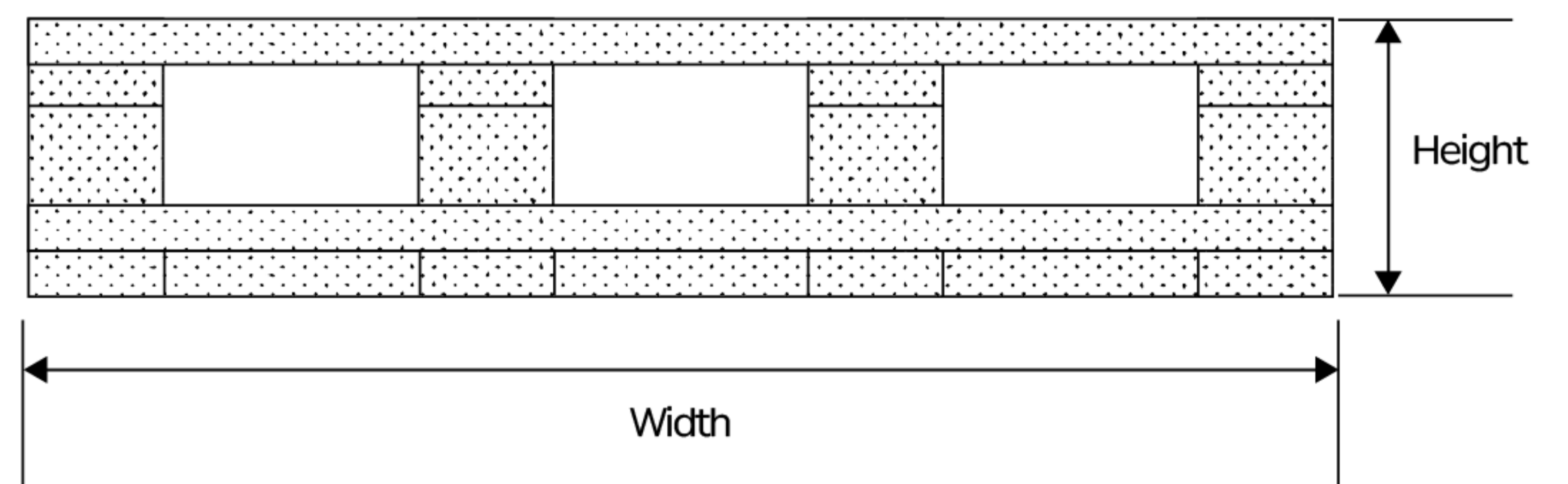

# Handling, Storage & Transportation Guidelines

To maintain product quality and ensure safe logistics operations, **Hanwha Solutions Wire & Cable** compounds must be handled, stored, and transported in accordance with the following guidelines.

## 1. Forklift Handling Instructions

- Forklift forks must be inserted from the **front or rear side of the pallet**, corresponding to the side where the **Hanwha Solutions logo is displayed on the carton**
- **Do NOT insert forks from the left or right side**, as forks may contact the carton banding and cause packaging damage.
- Ensure forks are **fully inserted and evenly positioned** before lifting
- Lift and lower pallets **slowly and carefully** to prevent impact, tilting, or load instability
- Use forklifts with **adequate load capacity** appropriate for the pallet weight

Improper forklift handling may result in packaging damage or product instability.



## 2. Pallet Stacking Limitations

**To ensure safe storage and prevent packaging deformation:**

Do not exceed the maximum stacking height specified for each packaging type

### Pallet Stacking Limitations

Packaging Type	Max Stacking
550 kg Carton	3 Pallets
650 kg Carton	3 Pallets
1,000 kg Carton	2 Pallets

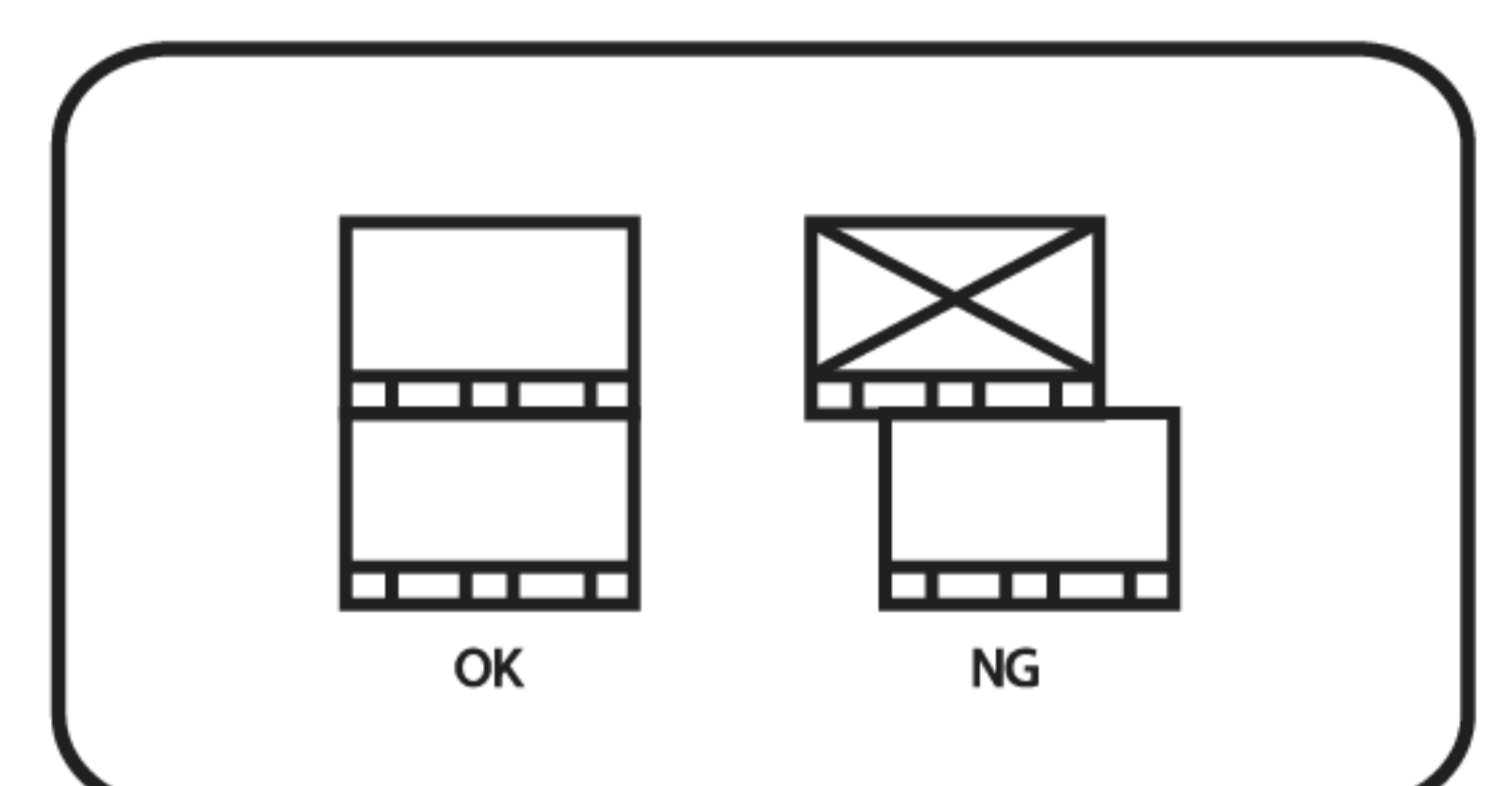
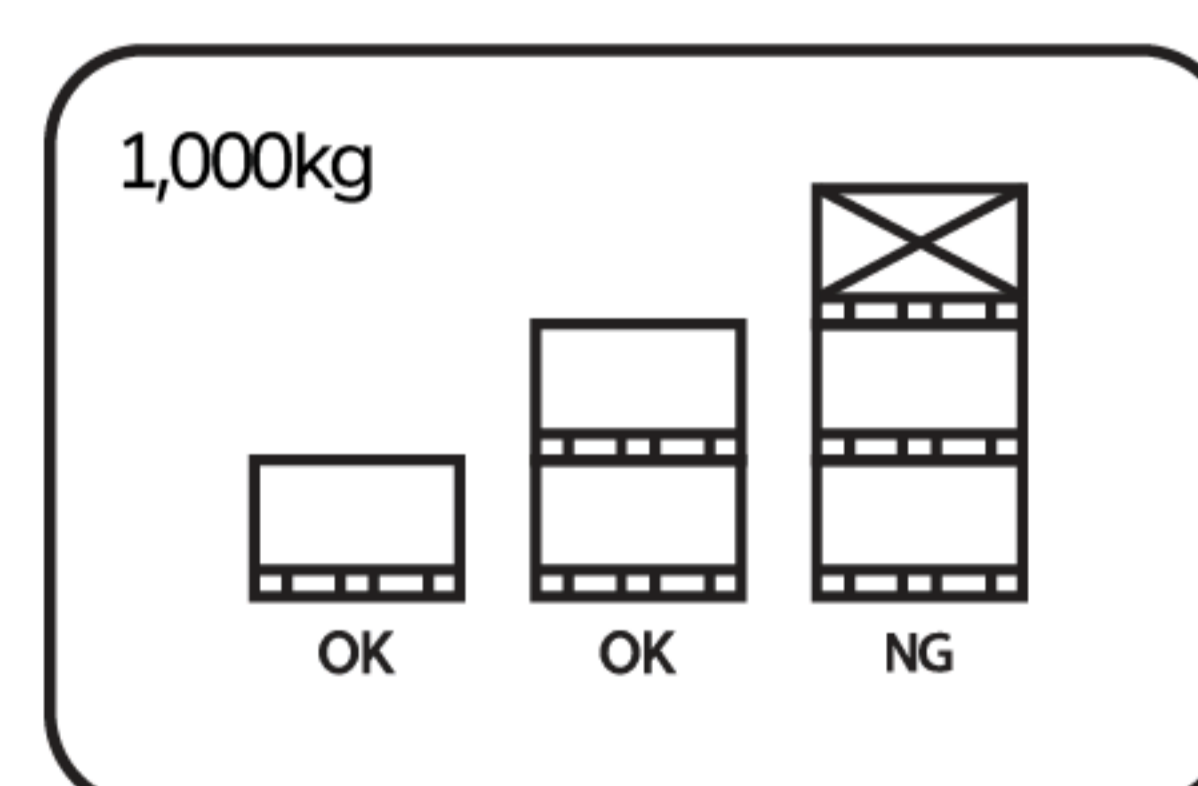
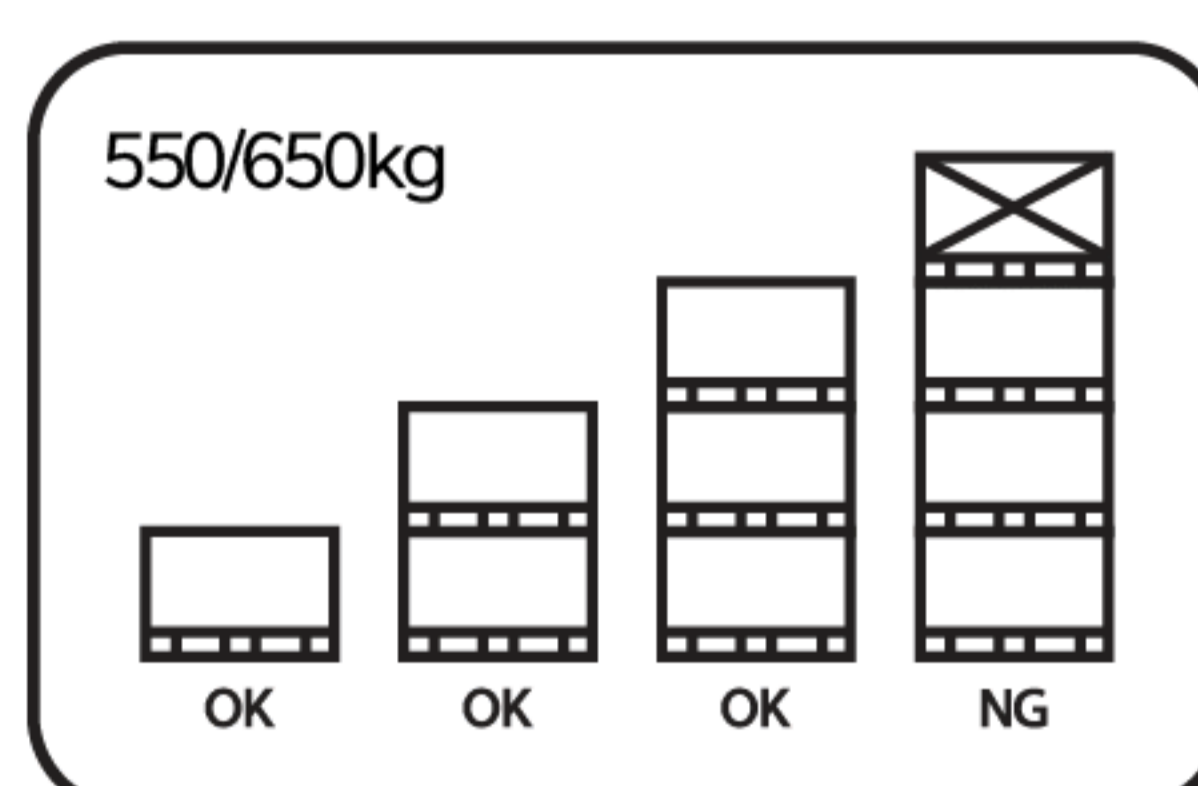

- Flexible packaging and other formats should follow specified pallet stability limits
- Always stack pallets on a flat, stable, and level surface
- Ensure pallets are properly aligned vertically
- Do not stack damaged pallets or cartons
- Avoid uneven or offset stacking

Exceeding stacking limits may result in packaging failure or safety hazards.

### 3. Storage Conditions

To preserve material performance and cleanliness:

- Store **indoors only**, in a clean and dry environment
- Maintain storage temperature between **10 °C and 30 °C**
- Keep products in their **original, unopened packaging**
- Protect from **direct sunlight, moisture, and outdoor exposure**
- Apply **FIFO (First-In, First-Out)** inventory management
- **Recommended storage period** : up to 18 months under recommended conditions

Improper storage conditions may affect product quality.



### 4. Moisture Control During Transportation

To prevent moisture-related quality issues during shipment, desiccants are installed inside containers.

#### Desiccant Installation

Container	Desiccant Sets	Total Units
20 ft	6 sets	24 units
40 ft	10 sets	40 units

Desiccants are positioned to ensure effective humidity control throughout transportation, helping maintain product integrity during long-distance shipments.

### 5. Responsibility Disclaimer

To preserve material performance and cleanliness:

**Hanwha Solutions** packages all products in accordance with internal quality standards and international logistics practices at the time of shipment.

**Hanwha Solutions** shall not be held responsible for damage, contamination, or product deterioration resulting from improper handling, storage, stacking, transportation, or environmental conditions after delivery.

All logistics operators, warehouse personnel, and customers are responsible for following the handling and storage guidelines provided in this document and applicable industry standards.

For additional guidance, please contact **Hanwha Solutions Wire & Cable Division**.



# Advanced Polymer Compounds for Cable Applications Wire & Cable Division



YOUTUBE



LINKEDIN